

Condor Products.

Technical Components Development & Design, Inc.

210 W. Stephenie Drive
Cortland, IL 60112
Phone: (815) 754-7418
Fax: (815) 754-7419

WebSite: www.condor-lift.com
Email: tcdd@condor-lift.com

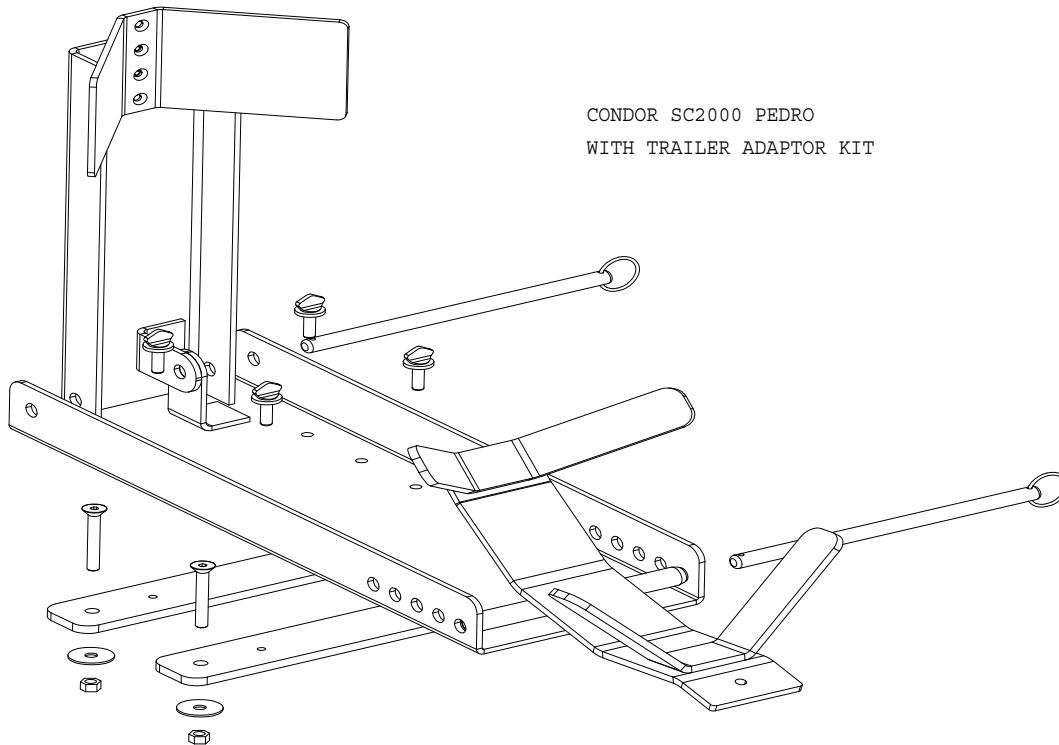

****Note: Cradle must be turned 180 degrees for installation.**

Condor_R SC2000 Trailer Only With Kit Wheel locking chock:

The Condor_R SC2000 Trailer Only Chock is a fully adjustable wheel locking system capable of accommodating front and rear wheel sizes from 14-22" / 80-220W. The patented locking mechanism effortlessly and securely supports your motorcycle in an upright position on all transportation Platforms. As a Trailer Chock it easily snaps on and off all transport platforms. Attaching and detaching the unit takes only a few seconds. It's dimensions in the upright position are 9" wide, 25" long and 15" high. Once folded, it becomes 9" wide, 25" long and 7" high. For more information or to order please GO TO: WWW.CONDOR-LIFT.COM OR CALL 1-800-461-1344.

User Instructions:

Confirm that the cradle is set in the optimized position setting (See **RECOMMENDED CRADLE SETTINGS**) for the entering tire and wheel. Adjustment of cradle is crucial for optimum retention. Optimum retention is achieved by trying different settings. (REFER TO CAUTION PARAGRAPH BELOW): Place unit in front of or behind motorcycle. Push or drive the motorcycle, centered into unit until the cradle of the Simple Chock has fully engaged the wheel. Once the wheel is cradled, proceed to push further into the Simple Chock until the wheel has engaged the front stop. If the optimum vertical support is achieved, the motorcycle will hold itself upright. If optimum retention is not achieved try different cradle settings. (REFER TO CAUTION PARAGRAPH BELOW): As an extra precaution, one may use the optional Velcro strap to strap the cradled wheel to the front stop. (Optional Velcro strap purchased separately.) Strap Velcro, if purchased, through the wheel and around the front stop below the upper front stop flange. For more information on use, refer to www.condor-lift.com

RECOMMENDED CRADLE SETTINGS:

The SC2000 is designed so that for every tire/wheel size within the ranges specified a minimum of 2 cradle settings be suitable. The optimum cradle setting for a specific tire would be, the setting that allows the cradle to tilt as far forward as possible without making contact with the unit's mounting surface or ground. The 2nd optimum setting would be the setting forward from the optimum setting away from the entry direction. If less retention is desired at any time due to too much retention or sticking, the cradle may be moved away from the entry direction one notch.

RACING APPLICATIONS:

For bikes with GP or low durometer front tire compounds, use the 6th and 5th cradle setting from the entry directions. For hot sticking tires us the 6th setting.

CAUTION: Always make sure that all fasteners are tight and all pins are in place prior to use. Understand the limitations of this product and do not exceed these limitations. Always make sure that the unit's cradle settings are optimum for the tire size of the motorcycle before use. For Sportbikes or Motorcycles with low hanging chin fairings, fenders, and cowlings, the cradle may need to be turned 180 degrees for additional clearance, so as not to make contact with a low hanging chin fairing, fender or cowling. For standard sportbike front wheel combinations, the 1,2,3, front settings may be suitable. If instructions are not clear, additional information is available at www.condor-lift.com or call 1-800-461-1344. Technical Components Development & Design is not responsible for any damage incurred by exceeding this product's limitations in structure and/or functionality.

One Year Limited Warranty:

This Condor™ Pit-Stop product warranty extends to the original consumer purchaser of the product. All illustrations and specifications contained in this manual are based on the latest product information available at the time of printing. Technical Components Development & Design, Inc. reserves the right to make changes at any time, without notice, in color, materials, equipment, options, specifications and models. Models may be shown with optional equipment. Further information may be obtained by contacting Technical Components Development & Design, Inc. @ #1-815-754-7418.

Return Policy: 15 day return policy applies. Merchandise may be returned within 15 days of purchase. Merchandise must be unused and in its original packaging. Customer will call TC Development for a Return Authorization number. Customer pays for freight return. Credit is given upon inspection of returned goods. A ten percent re-stocking fee applies to all returned merchandise

Warranty Duration:

This product is warranted to the original consumer purchase for a period of one (1) Year from original purchase date.

What is not covered:

Our warranty for your product will not cover abnormal wear of parts, damage resulting from negligent use or misuse of the product, use contrary to operating instructions, or disassembly, repair or alteration by any person other than an authorized service station. We shall not be liable for any incidental or consequential damages for breach of by express or implied warranty on your product.

How your state's law may apply:

Some states do not allow limitations on how long any implied warranty lasts or the exclusion or limitation of incidental or consequential damages. So the above limitation may not apply to you. This warranty gives you specific legal rights, and you may also have other rights, which may vary from state to state.

Thank you for purchasing the Condor Pit-Stop/Trailer-Stop.

Condor™ is a trademark of Technical Components Development & Design, Inc.
The Condor Pit-Stop / Trailer-Stop is US Patented & International Patent Pending.
210 W. Stephenie Drive
Cortland, IL 60112
Phone: (815) 754-7418
Fax: (815) 754-7419
WebSite: www.condor-lift.com