



Custom Dynamics® Dynamic Load Isolator Installation Instructions

We thank you for purchasing the Custom Dynamics® Dynamic Load Isolator. Our products utilize the latest technology and high quality components to ensure you the most reliable service. We offer one of the best warranty programs in the industry and we back our products with excellent customer support, if you have questions before or during installation of this product please call Custom Dynamics® at 1(800) 382-1388.

Part Number: CD-DLI-TKE

Package Contents:

- Dynamic Load Isolator (DLI) (1)
- Instructions (1)

Fits: 2014-2025 Harley-Davidson® Tri Glide (FLHTCUTG), 2015-2025 Freewheeler (FLRT), and 2023-2025 Road Glide 3 (FLTRT).

COMPATIBLE WITH ANY ELECTRICAL ACCESSORY UP TO 10 AMPS.

30 AMP TOTAL MAXIMUM OUTPUT CAPACITY.



ATTENTION



Please read all Information below before Installation

Warning: Do not exceed 30 amp load. Doing so could cause the unit to overheat.

Important: Module must be secured after installation.

Important: DO NOT attempt to make changes to the input side of the Dynamic Load Isolator. Doing so will cause malfunction of unit.

Note: If a Brake Strobe unit is plugged in front (before) the DLI, both the bike's rear harness and any brake accessories attached on the output side of the DLI will have the brake strobe pattern. If the Brake Strobe unit is plugged in behind (after) the DLI, only the rear harness of the bike will have the brake strobe pattern.

Note: Each wire port can accept multiple wires depending on the gauge of the wire.

Note: While some wiring examples are included, follow the directions included with each accessory added to the Dynamic Load Isolator.

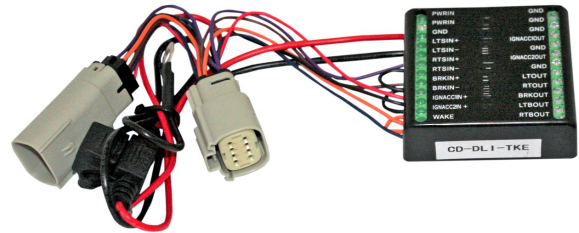

Installation:

1. Secure motorcycle on level surface.
2. Remove seat.
3. Disconnect negative battery cable from the battery.
4. Locate and unplug the lighting connector to the rear fender under the seat. This may be located under the rear shock adjustment knob.
5. Plug the DLI™ module, in-line, into the rear lighting harness plug and the bike's main wiring harness.
6. Attach the single Red fusible wire of the Dynamic Load Isolator to the positive side of the battery.
7. Attach the single Black wire of the Dynamic Load Isolator to the ground side of the battery.
8. Select the desired functions of the Dynamic Load Isolator. Shown in **Diagram on Page 2**.
9. Use a small straight slot or Phillips screw driver in the output port selected and turn the screw counter clockwise until the wire slot is open. Shown in **Figure 1 on Page 2**.
10. Place the wire in the port and turn the screw clockwise until it is tight against the wire. Shown in **Figure 2 on Page 2**.
11. Reconnect the negative battery cable to the battery.
12. Check operation of all lighting before riding.
13. Locate a secure place for the Dynamic Load Isolator unit that will not interfere with the secure placement of the seat.
14. Reinstall seat.

Installation Instructions - Page 2

DLI Output Port Functions:

GND: Four Ground outputs.

IGNACCOUT 1 & 2: 12 volt switchable power sources that can be used for accessories or running light operation.

LTOUT: Output follow motorcycle's rear turn signal circuit operation. Turn and Brake.

RTOUT: Output follow motorcycle's rear turn signal circuit operation. Turn and Brake.

BRKOUT: Brake signal operation only.

LTBOUT: Left turn signal and Brake operation with turn signal over riding the brake signal for the left side. The right side will still receive a brake signal.

RTBOUT: Right turn signal and brake operation with turn signal over riding the brake signal for the right side. The left side will still receive a brake signal.

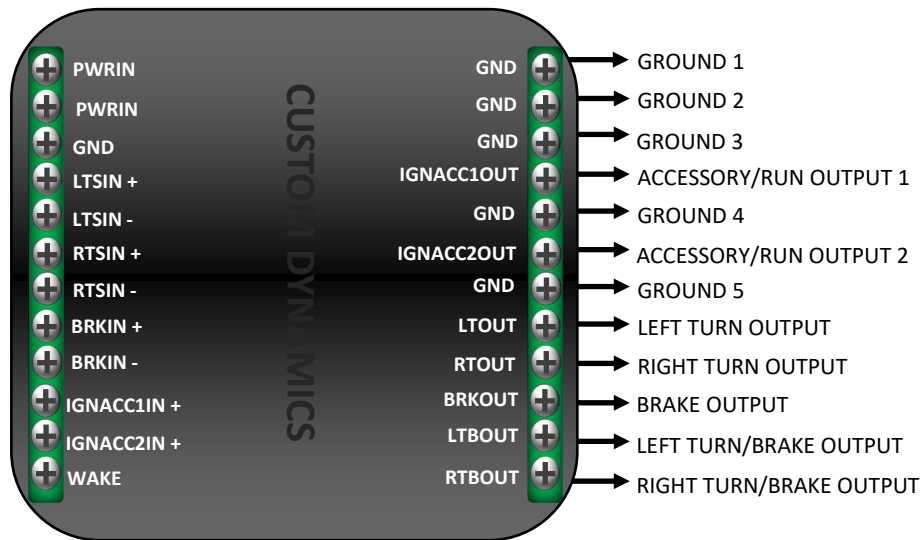

Use a small straight slot screw driver in the output port selected and turn the screw counter clockwise until the wire slot is open.

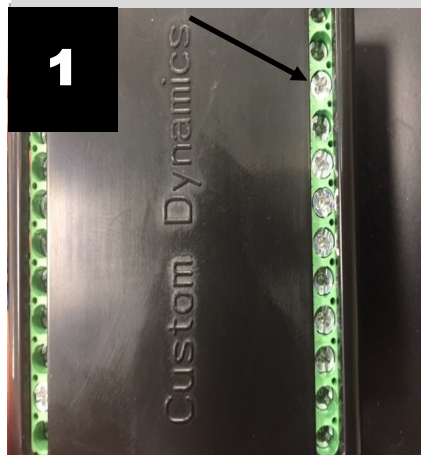

Output wire ports.



4 Pin Trailer Harness

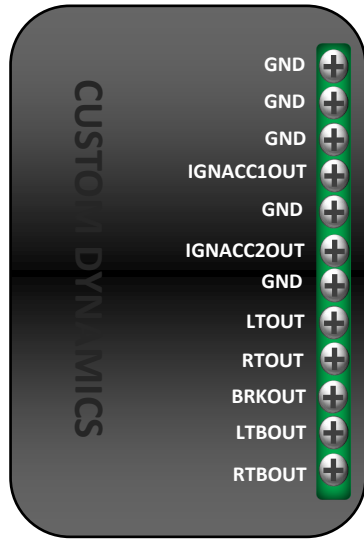

4 Pin Trailer Harness (optional):

- White wire - Ground
- Green wire - Right turn signal and brake signal
- Yellow wire - Left turn signal and brake signal
- Brown wire - Running light circuit

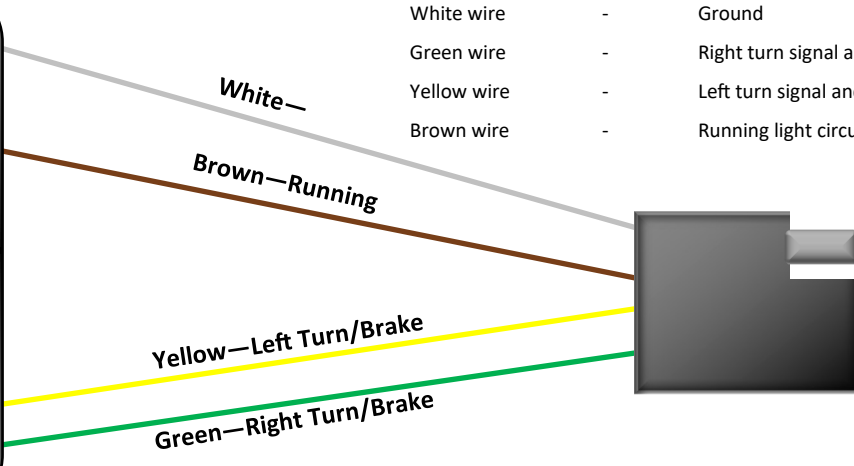

Run Operation:

Single Intensity LEDs

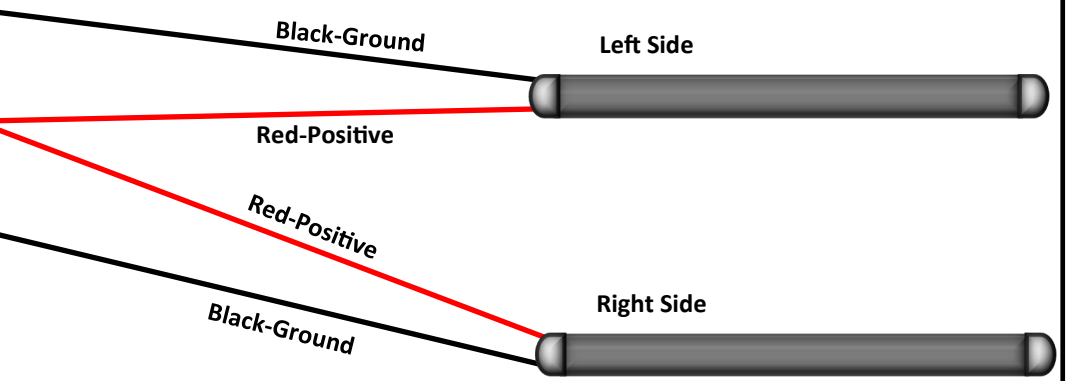
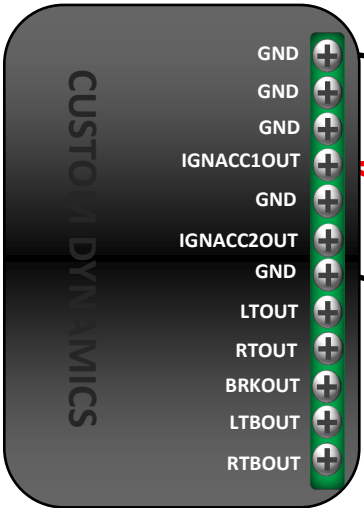

Turn-Brake Operation:

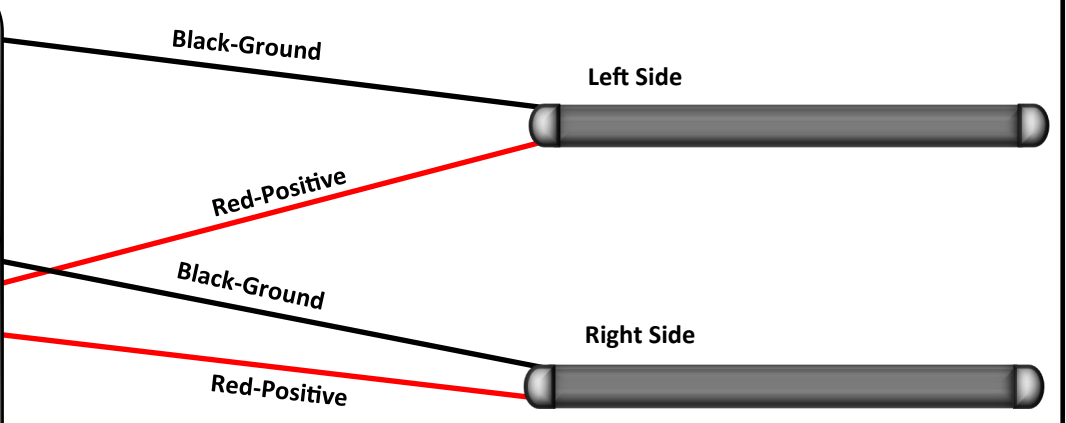
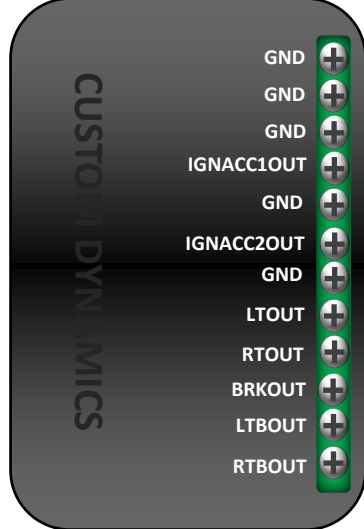

Installation Instructions - Page 4

Dual Intensity LEDs

Run-Brake Operation:

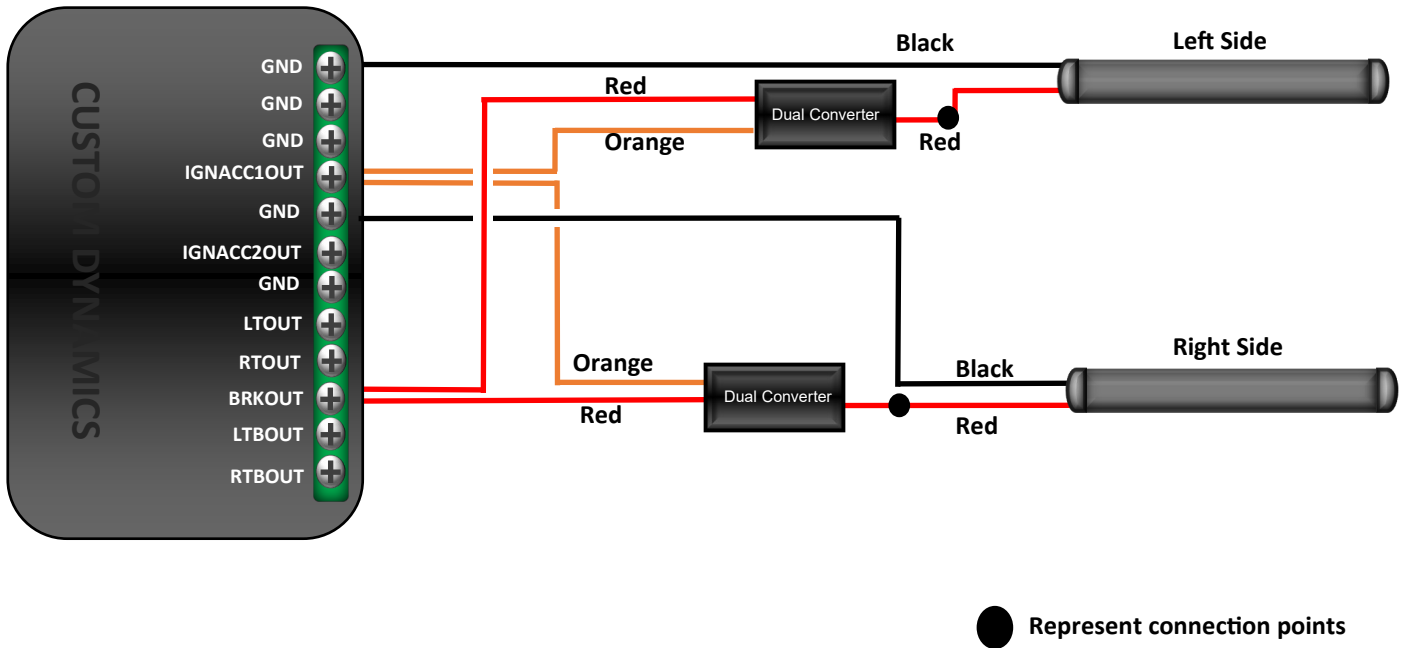

Dual Intensity LEDs

Run-Brake-Turn Operation:

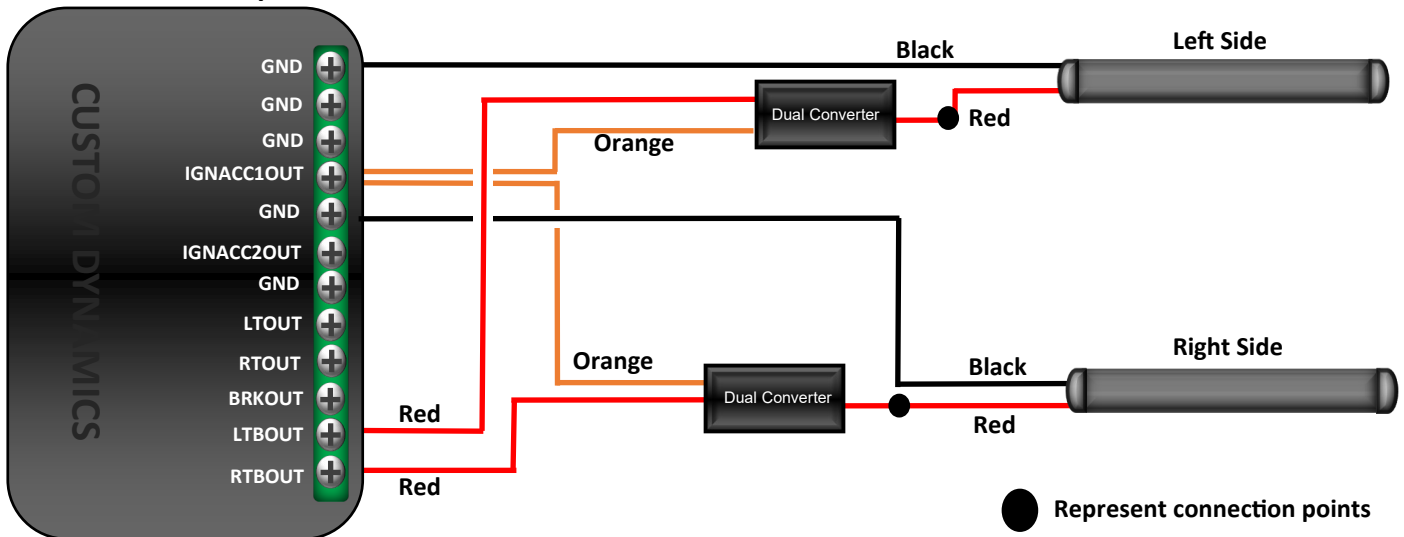

Note: While some wiring examples are included, follow the directions included with each accessory added to the Dynamic Load Isolator.