



Custom Dynamics® Low Profile BAGZ™ Saddlebag LED Lights Installation Instructions

We thank you for purchasing the Custom Dynamics® Low Profile Bagz™ Saddlebag LED Lights. Our products utilize the latest technology and high quality components to ensure you the most reliable service. We offer one of the best warranty programs in the industry and we back our products with excellent customer support, if you have questions before or during installation of this product, please call Custom Dynamics® at 1(800) 382-1388.

Part Numbers: CD-LP-BCM-R CD-LP-BCM-S

Package Contents:

- Low Profile BAGZ™ Saddlebag LED Lights (2)
- BCM Y Harness Adapter w/ Plugs (1)
- 4" Cable Ties (10)
- Cable Tie Holders (6)
- Instructions (1)

Fits: 2014-2024 Harley-Davidson® Ultra Limited (FLHTK), 2014-2023 Street Glide (FLHX), Street Glide Special (FLHXS), 2015-2023 Road Glide (FLTRX), Road Glide Special (FLTRXS), 2017-2025 Road King Special (FLHRXS), 2014-2022 Road King (FLHR), 2022-2023 Street Glide ST (FLHXST), Road Glide ST (FLTRXST) & CVO™ Road Glide Limited (FLTRKSE), 2020-2024 Road Glide Limited (FLTRK), 2015-2022 CVO™ Street Glide (FLHXSE), 2018-2022 CVO™ Road Glide (FLTRXSE), 2019-2022 Electra Glide Standard (FLHT), 2014-2019 Electra Glide Ultra Classic (FLHTCU), 2015-2016 Ultra Classic Lo (FLHTCUL) & CVO™ Road Glide Ultra (FLTRUSE), 2016-2019 Road Glide Ultra (FLTRU), 2015-2018 Ultra Limited Lo (FLHTKL), 2014-2021 CVO™ Limited (FLHTKSE) and 2014 CVO™ Road King (FLHRSE). **Functions as Run/Brake/Turn** on 2014-2024 Harley-Davidson® Ultra Limited (FLHTK), 2014-2023 Street Glide (FLHX), Street Glide Special (FLHXS), 2015-2023 Road Glide (FLTRX), Road Glide Special (FLTRXS), 2017-2025 Road King Special (FLHRXS), 2014-2019 Ultra Classic (FLHTCU), Ultra Classic Lo (FLHTCUL), Ultra Limited Lo (FLHTKL), Road Glide Ultra (FLTRU), 2020-2024 Road Glide Limited (FLTRK), 2016 Road Glide Ultra CVO (FLTRUSE), 2022-2023 Road Glide Limited CVO (FLTRKSE) and 2016-2022 Limited CVO (FLHTKSE). **Functions as Run/Turn** on 2014-2023 Harley-Davidson® Road King (FLHR), Street Glide ST (FLHXST), Street Glide CVO (FLHXSE), Road Glide ST (FLTRXST), Road Glide CVO (FLTRXSE), 2014 Road King CVO (FLHRSE), 2015 Road Glide Ultra CVO (FLTRUSE), 2014-2015 Ultra Limited CVO (FLHTKSE), 2014-2018 Electra Glide Police (FLHTP) and 2019-2022 Electra Glide Standard (FLHT).



Installation:

1. Test fit the Low Profile BAGZ™ Saddlebag LED Lights, on each bag. The light should mount a couple millimeters below the bottom edge of the lid when the lid is closed. Mark the location with a grease pencil.
2. Using denatured alcohol, clean the surface mounting area. Allow 1-2 minutes to dry.
3. Remove the red adhesive backing and install the lights on the left and right saddlebags. Press into place making sure the adhesive tape is making contact with the saddlebag. **Note: Do not apply too much pressure in the center of the Low Profile BAGZ™ Saddlebag LED Lights. This can cause the lens to crack and will not be covered under warranty.**
4. Remove both saddlebags from the motorcycle.
5. Clean the surface area locations for the tie wrap holders with isopropyl denatured alcohol. Remove paper backing from cable tie holders and press into place. Shown in **Figure 1**.



6. Route wires from bag light to each Cable Tie Holder location and secure with supplied Cable Ties.
7. Remove seat from bike and locate rear main wire harness.
8. Plug BCM Y harness adapter into rear wiring harness.
9. Route the wires on the harness adapter out from under the seat and towards saddlebags.
10. Reinstall saddlebags. Connect 3 pin plugs from bag lights to Y Adapter making sure female with violet wire plugs in male with violet wire, and female with brown wire plugs into male with brown wire. Shown in different **Configurations on Page 2**.
11. Secure wires with supplied Cable Ties to prevent from being cut, frayed or pinched and reinstall the seat.
12. Perform a BCM sync by turning key on, turn 4 way hazards on, turn key off. Allow hazards to run for 3-4 minutes. Turn Key on, Turn Hazards off, Turn Key off.
13. Test the Custom Dynamics® Low Profile BAGZ™ Saddlebag LED Lights for proper operation.



ATTENTION

Please read all Information below before Installation

Disclaimer: Removal of our saddlebag lights after installation, may cause permanent damage to the finished surface area of the saddlebag.

Warning: Disconnect negative battery cable from battery; refer to owner's manual. Failure to do so may result in electrical shock, injury or fire. Secure negative battery cable away from positive side of battery and all other positive voltage sources on motorcycle.

Safety First: Always wear appropriate safety gear including safety glasses when performing any electrical work. It is highly recommended that safety glasses be worn throughout this installation process. Be sure motorcycle is on level surface, secure and cool.

Important: This product is designed and intended for use as auxiliary lighting only. It is NOT intended to replace any original equipment lighting installed on the vehicle and should not be used for that purpose. This product must be wired so that it does not interfere with any original equipment lighting.

Important: Ambient install temperature must be 60 degrees F or higher. Allow 24 hours for tape to cure before washing or prolonged use of motorcycle.

Questions? Email: info@CustomDynamics.com or Call us at: 1 (800) 382-1388 M-TH 8:30AM-5:30PM / FR 9:30AM-5:30PM EST

Installation Instructions - Page 2

Run-Brake Modification

For 2014 CVO™ Road King, 2015-2021 CVO™ Street Glide, 2018-2022 CVO™ Road Glide, 2014-2022 Road King® Standard, 2014-2015 Limited CVO™ & 2015 Road Glide Ultra CVO™ 2022-2023 Road Glide ST, 2022-2023 Street Glide ST.

*Purple and Brown Wires going from the 3 Pin Connectors to the Y Harness must be cut and moved from the Violet and Brown to the Red Connections can easily be made using Posi-Tap™ connectors (Sold Separately).

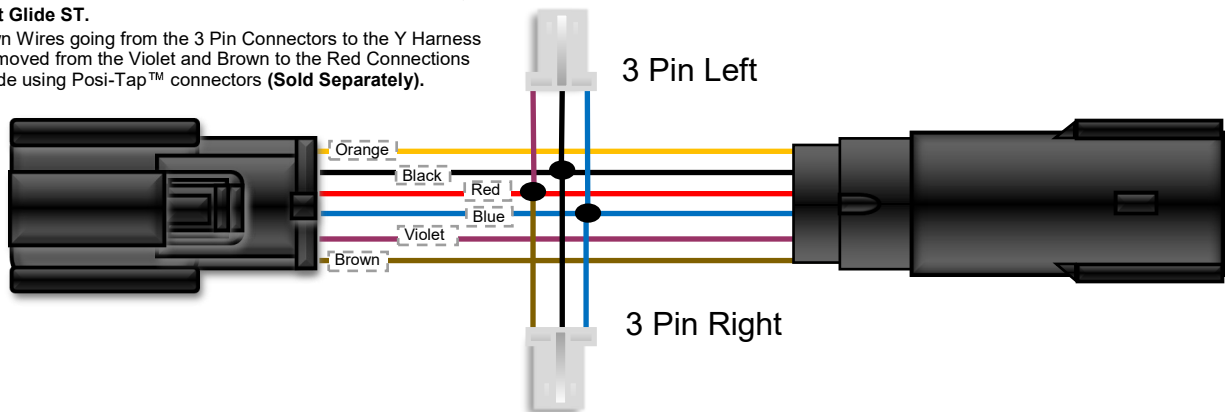

Run-Brake-Turn Modification

For 2014-2022 Road King® Standard, 2014-2015 Limited CVO™ & 2015 Road Glide Ultra CVO™ 2014 CVO™ Road King, 2022-2023 Road Glide ST, 2022-2023 Street Glide ST.

Plug-N-Play with SMART Triple Play® accessory plugs

*SMART Triple Play® with accessory plugs required. The provided BCM Y harness will not be used. The two 3 pin connectors that extend from the output side of the Smart Triple Play® module allow for plug and play installation. Simply plug in the left side (violet) and right side (brown) female connectors from the Smart Triple Play® to the corresponding male connectors on the product.

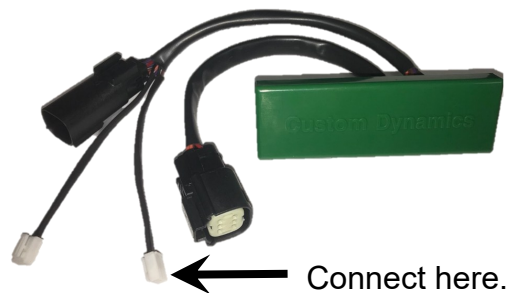
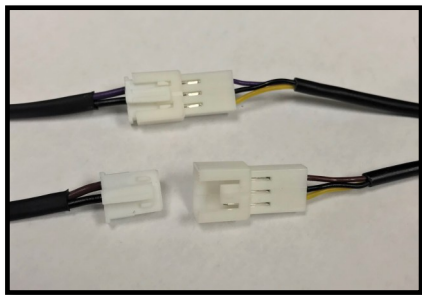

SMART Triple Play® without accessory plugs

*SMART Triple Play® without accessory plugs required. On the BCM Y Harness Adapter, the Blue wires going to both three pin connectors must be cut and capped off. BCM Y Harness Adapter must be installed on output side of SMART Triple Play®

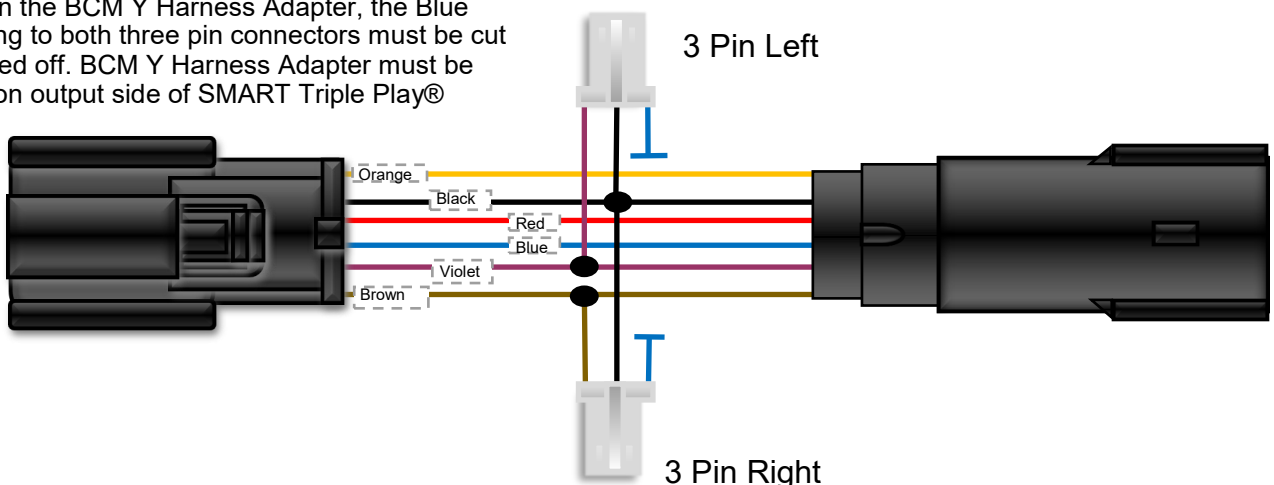

Installation Instructions - Page 3

Run-Brake-Turn modification with GEN-SMART-TPU-14CVO

2014 CVO™ Road King, 2015-2022 CVO™ Street Glide & 2018-2022 CVO™ Road Glide

Note 1:

Cut and remove the 3 pin plug from each LED BAGZ™ light to expose the black, yellow, and brown (right side) or violet (left side) wires. Cap off the yellow wire from each BAGZ™ light. Connect the pigtail output wires from the Smart Triple Play® using the supplied Posi-Lock™ connectors to the exposed black and brown (right side) or (left side) violet wires on the Custom Dynamics® BAGZ™ LEDs.

Note 2:

Cut the license plate light harness and connect the Blue and Black wires with the Posi-Lock™ installed on the Smart Triple Play® to side of the license plate harness going to the license plate light. Cap off the other side of the license plate harness wires with heat shrink and tuck it into factory conduit.

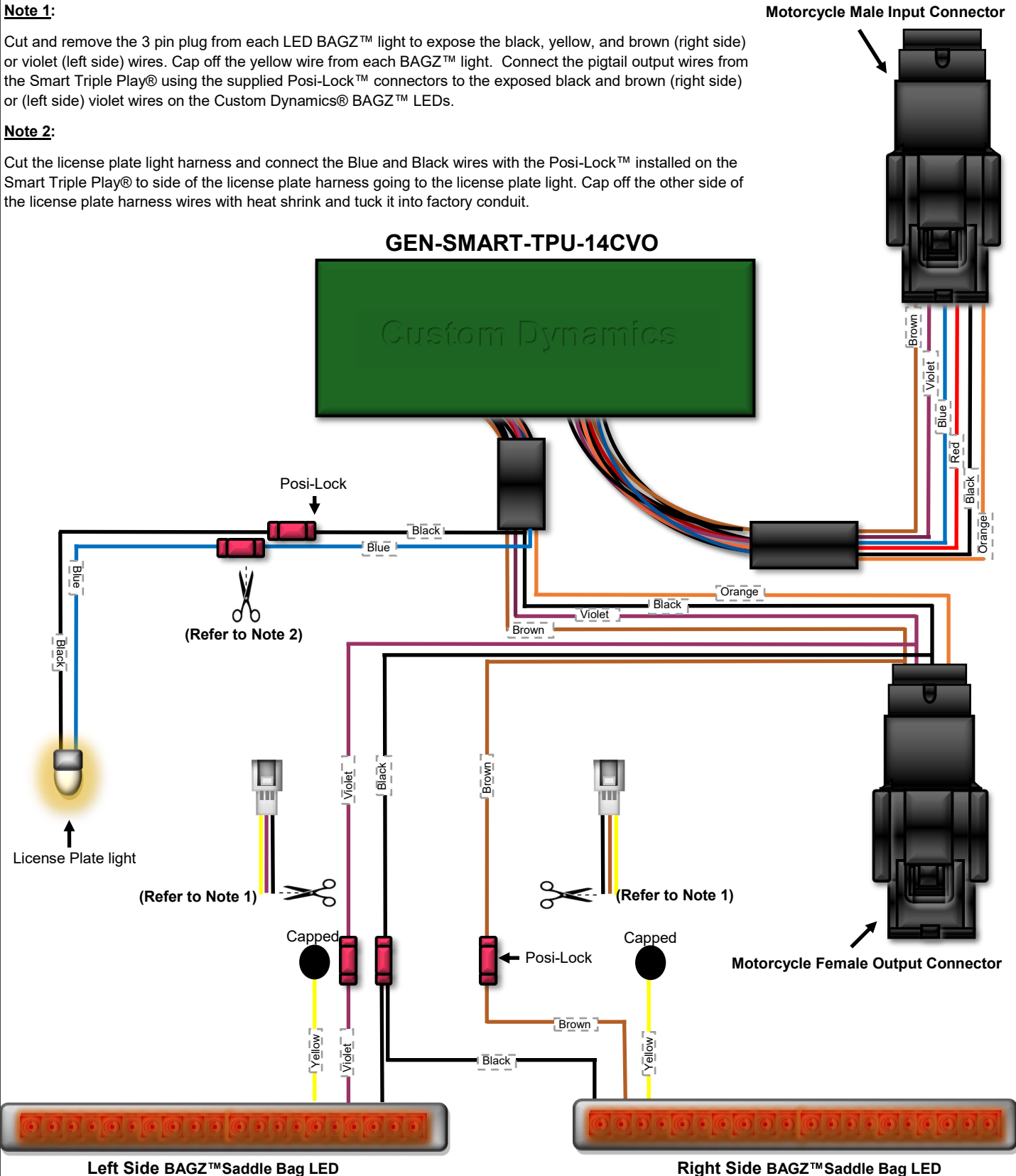

Questions? Email: info@CustomDynamics.com or Call us at: 1 (800) 382-1388 M-TH 8:30AM-5:30PM / FR 9:30AM-5:30PM EST