



Custom Dynamics® Saddlebag LED Latch Lightz™ Installation Instructions

We thank you for purchasing the Custom Dynamics® Saddlebag LED Latch Lights. Our products utilize the latest technology and high quality components to ensure you the most reliable service. We offer one of the best warranty programs in the industry and we back our products with excellent customer support, if you have questions before or during installation of this product please call Custom Dynamics® at 1(800) 382-1388.

Part Numbers: CD-LATCH-SS6-R
CD-LATCH-SS6-S

Package Contents:

- Saddle Bag LED Latch Lightz™ (2)
- SS6 Y Harness Adapter w/ Plugs (1)
- Quick Disconnect Harness (2)
- 4" Tie Wraps (10)
- Tie Wrap Holder (8)
- Foam Strip (2)
- Rubber Grommet (2)
- P-Clamps (2)
- JAE Connectors (2)

Fits: 2010-2013 Harley-Davidson® Street Glide (FLHX) and Road Glide Custom (FLTRX).

Does not fit CVO™ models.

Note: Lights are designed to operate as Run/Brake. However, lights can be configured to operate as Run/Turn or Run/Brake/Turn. **See page 3 & 4 for alternative configurations.**



Please read all Information below before Installation

Warning: Disconnect negative battery cable from battery; refer to owner's manual. Failure to do so may result in electrical shock, injury, or fire. Secure negative battery cable away from positive side of battery and all other positive voltage sources on vehicle.

Safety First: Always wear appropriate safety gear including safety glasses when performing any electrical work. It is highly recommended that safety glasses be worn throughout this installation process. Be sure vehicle is on level surface, secure and cool.

Important: This product is designed and intended for use as auxiliary lighting only. It is NOT intended to replace any original equipment lighting installed on the vehicle and should not be used for that purpose. This product must be wired so that it does not interfere with any original equipment lighting.

Important: Ambient install temperature must be 60 degrees F or higher. Allow 24 hours for tape to cure before washing or prolonged use of vehicle.

Note: The Y Harness Adapter must be plugged into the output (behind) any Smart Signal Stabilizer™/load equalizer or any brake strobe modules.

Note: Lights are designed to operate as **Run/Brake**. However, lights can be configured to operate as Run/Turn or Run/Brake/Turn. See page 3 for alternative configurations.

Installation:

1. Secure motorcycle on level surface. Remove seat. Disconnect negative battery cable from the battery.
2. Remove the left side cover, locate and unplug the rear lighting connector to the rear fender.
3. Plug the provided SS6 Y Harness Adapter, in-line, into the rear lighting harness and into the bike's main wiring harness.
4. Open saddle bag lid and remove any personal items from the saddle bag.
5. With the saddle bag open, disconnect the check strap from the lid of the saddlebag. Save the hardware for reassembly. The saddlebag lid will need to remain fully open to the outside of the saddlebag. Take protective measures so the saddlebag and/or lid are not damaged during the rest of the installation.
6. Remove the hinge cover from the hinge and locking mechanism.
7. With the hinge cover laying face down on a flat surface, place the hole templet on the back of the hinge cover and mark the hole location. See Photo 1
8. Carefully drill a 1/4" hole where you marked it in the previous step. Do not drill all the way through the reflector, you only want to drill through the hinge cover.
9. Use a small screwdriver and push the reflector out from the back side of the hinge cover where you drilled the hole. See Photo 2.
10. With the reflector removed, enlarge the hole you drilled in step 8 to 3/8". Clean any debris and adhesive from the area where the reflector was removed.
11. Lay the hinge cover on the hinge and mark the hole location on the hinge as shown in Photo 3. Drill a 3/8" hole at the marked location.



Questions? Call us at: 1 (800) 382-1388 M-TH 8:30AM-5:30PM / FR 9:30AM-5:30PM EST

Installation Continued:

12. Wipe the reflector area down with denatured alcohol and let dry.
13. Route wire from Latch Lightz™ through the hole you drilled in the hinge cover and hinge. Remove the protective red film from the back of the Latch Lightz™. Align the Latch Lightz™ in the reflector area and press into place.
14. Reinstall the hinge cover on the saddle bag hinge. Slide the Latch Lightz™ wire into the provided P-Clamps. Install the P-Clamps on the stud near the 1/4" hole drilled in Step 8. See Figure 4A.
15. Install the provided foam strip on the top outside lip of the saddle bag as shown in Photo 4B.
16. Route wire from Latch Lightz™ over the foam pad and around to the front of the saddle bag towards the locking latch. Secure the wire to the inside of the saddlebag using the provided tie wrap holders and tie wraps as shown in Photo 5. Wipe the mounting location of the tie wrap holder with denatured alcohol and let dry before pressing into place.
17. Remove saddlebags from the motorcycle. Transfer the saddlebags to a protected work area to prevent scratches.
18. Using a grease pencil, mark desired drill point for the Latch Lightz™ wire to exit the saddle bag. It is recommended the drill hole is located approximately 1" below the saddle bag latch as shown in Photo 6. Apply masking tape to the outside of the saddlebag at the marked drill point.
19. Using a 9/16 drill bit, drill a hole through the marked drill hole on each saddlebag. Drill from the outside of the saddlebag to the inside then remove masking tape. It is recommended to start with a smaller drill bit and work up to a 9/16 drill bit.
20. Install the provided rubber grommet into the hole you drilled in the previous step.
21. Route wire from each Latch Lightz™ through the rubber grommets and out the backside of the saddle bag.
22. Install the provided JAE connectors onto the pre-pinned wires from each Latch Lightz™ by pushing the pins into the connector ports according to Photo 7 (locking tab oriented at top of JAE connector): Pins should snap in place and not pull back out of connector when installed correctly.
23. Reinstall saddlebags and plug in the male JAE connectors from each Latch Lightz™ to the female JAE connectors (black) on the Quick Disconnect Harness.
24. Connect the Quick Disconnect Harness to the SS6 Y Harness.
25. Secure wires under the seat with tie wraps to secure wires from becoming cut, frayed, or pinched.
26. Reinstall motorcycle seat and left side cover, test operation of all lighting before riding.

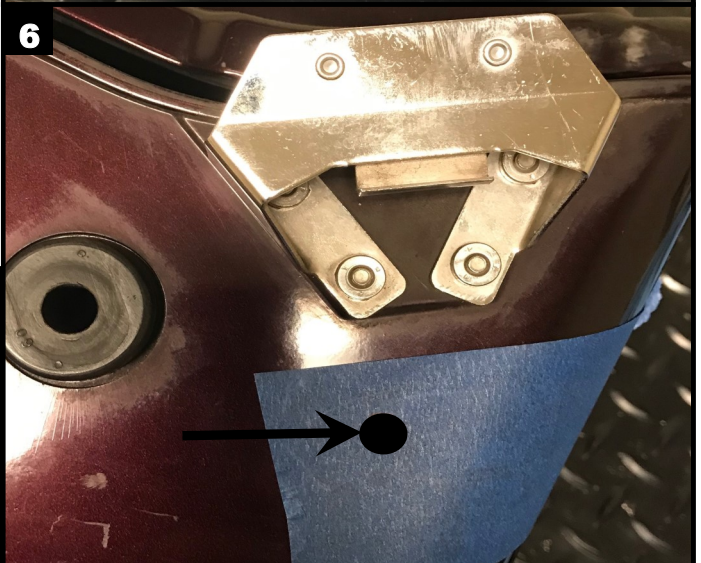
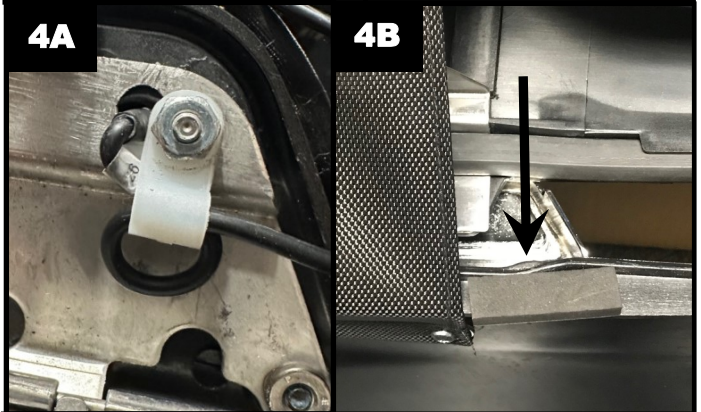

Questions? Call us at: 1 (800) 382-1388 M-TH 8:30AM-5:30PM / FR 9:30AM-5:30PM EST

Run, Brake and Turn function Requires P/N: PB-TRI-2

Custom Dynamics® dual intensity LED TriBar with SMART Triple Play®

Run-Brake-Turn Plug-N-Play with SMART Triple Play® Included with PB-TRI-2

***Requires** Custom Dynamics® dual intensity LED TriBar with SMART Triple Play® **with** accessory plugs. The provided SS6 Y harness **will not** be used. The two 3 pin connectors that extend from the output side of the Smart Triple Play® module allow for plug and play installation. Simply plug in the left side (purple) and right side (brown) female connectors from the Smart Triple Play® to the corresponding male connectors on the product.

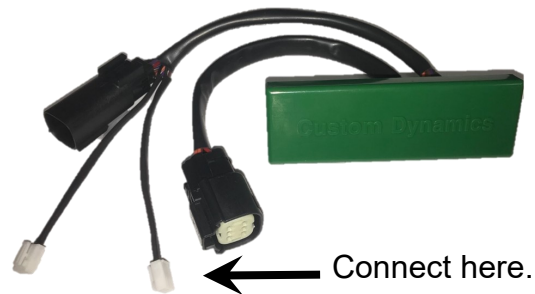
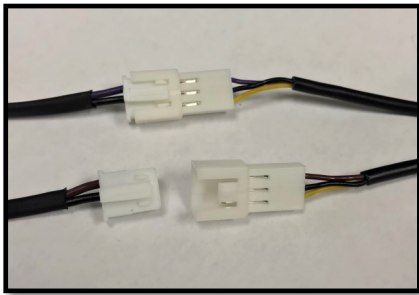

Run-Brake-Turn With Modification

***Requires** Custom Dynamics® dual intensity LED TriBar with SMART Triple Play® **without** accessory plugs required. On the SS6 Y Harness Adapter, the Blue wires going to the two 3 pin connectors must be cut and capped off. Brown wire of the 3 pin connector should be cut where it meets the Red wire and relocated to Brown harness adapter wire. The Purple wire of the 3 pin connector should be cut where it meets the Red wire and relocated to Purple harness adapter wire. Connections can easily be made using Posi-Tap™ connectors (*Sold Separately*)

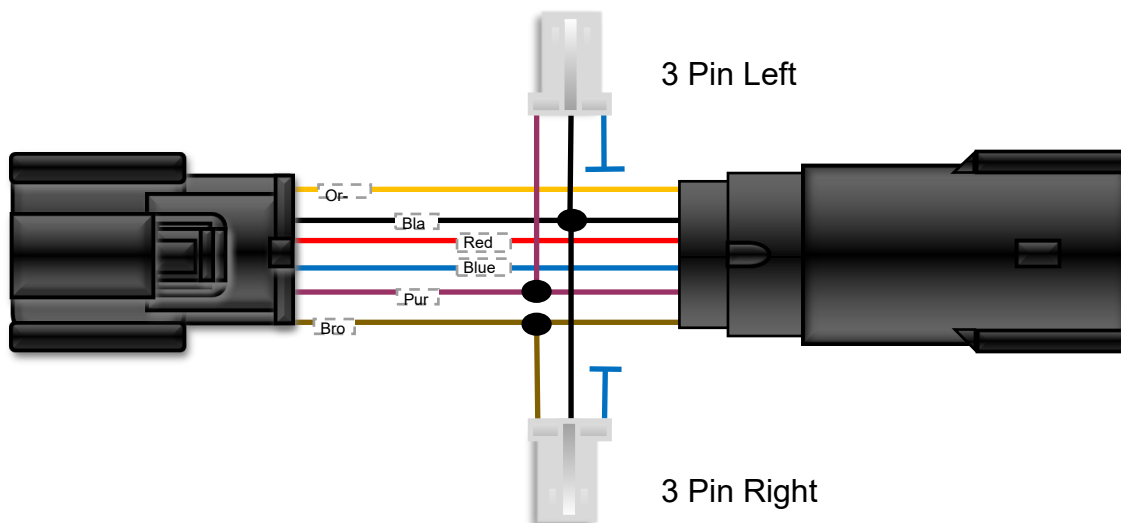

Installation Instructions - Page 4.

Run-Turn Configuration

*On the SS6 Y Harness Adapter, the Brown wire of the 3 pin connector should be cut where it meets the Red wire and relocated to Brown wire and Purple wire of the 3 pin connector should be cut where it meets the Red wire and relocated to Purple connector wire. Connections can easily be made using Posi-Tap™ connectors (*Sold Separately*) See photo below for reference.

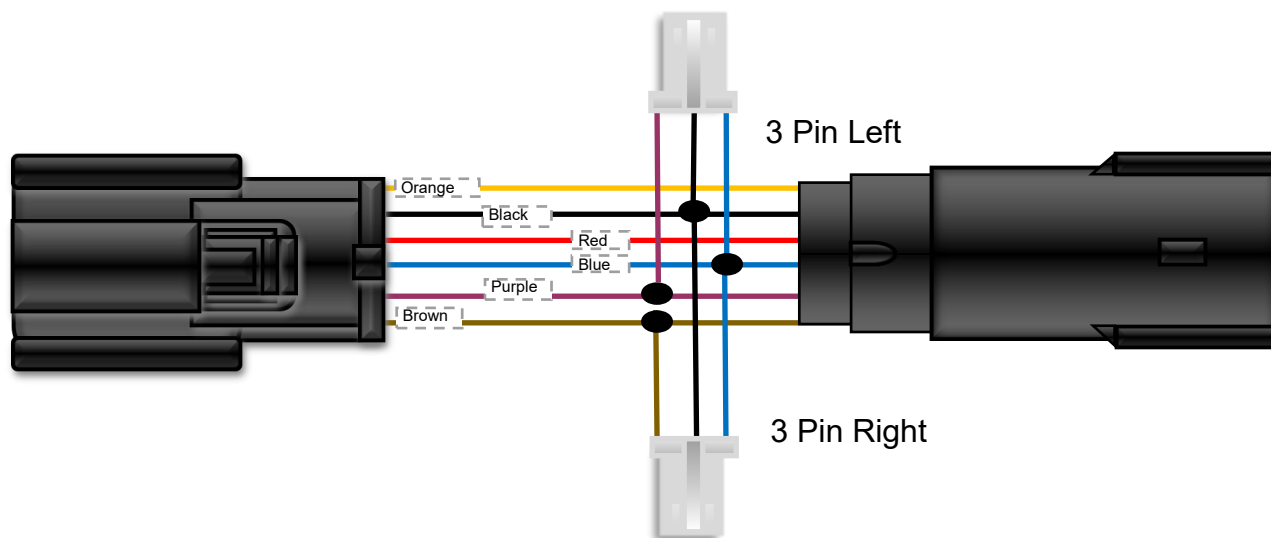

Package Contents

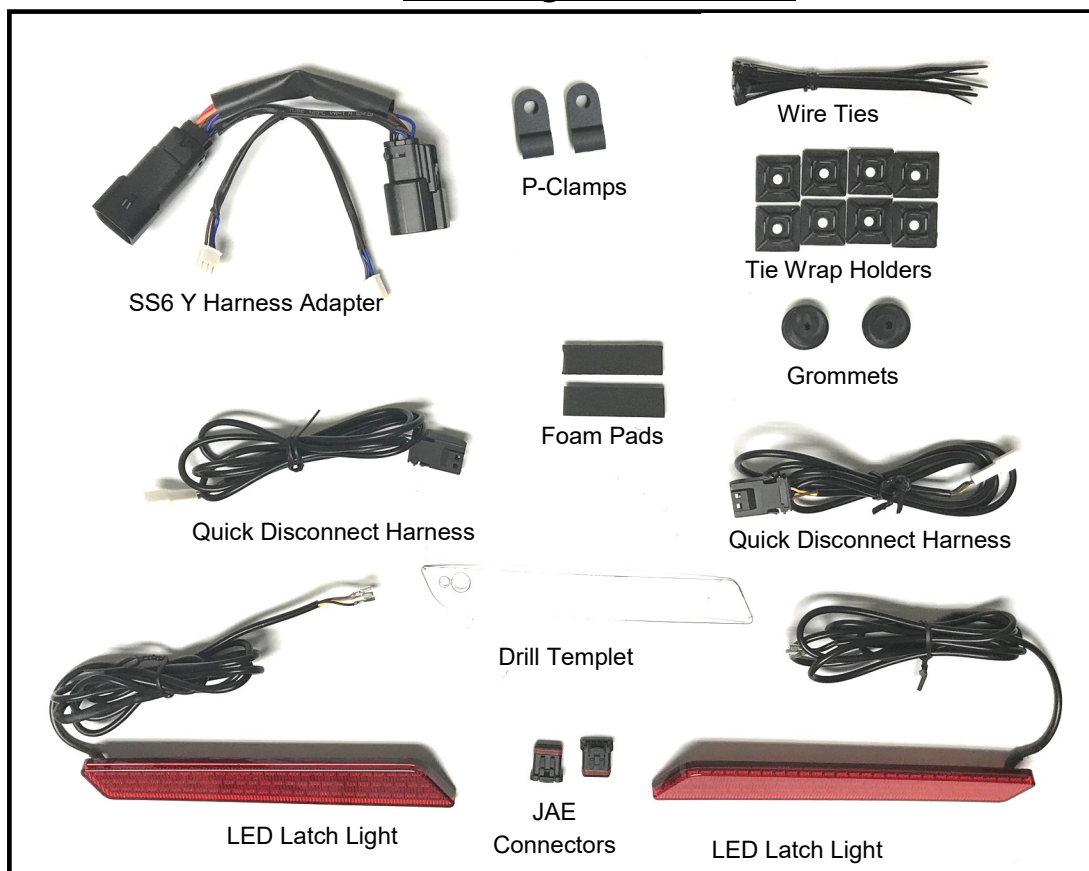

Questions? Call us at: 1 (800) 382-1388 M-TH 8:30AM-5:30PM / FR 9:30AM-5:30PM EST