



Custom Dynamics® TruBEAM® LED Headlight Installation Instructions

We thank you for purchasing the Custom Dynamics® TruBEAM® LED Headlight. Our products utilize the latest technology and high quality components to ensure you the most reliable service. We offer one of the best warranty programs in the industry and we back our products with excellent customer support, if you have questions before or during installation of this product please call Custom Dynamics® at 1(800) 382-1388.

Part Number: CDTB-7-B CDTB-7-C

Package Contents:

- TruBEAM® LED Headlight (1)
- Instructions (1)

Fits: 1981-2024 Harley-Davidson® Electra Glide/Ultra (FLHT) models including CVO™, 1997-2022 Road King (FLHR), Road King Classic (FLHRC), 2017-2025 Road King Special (FLHRXS), 2014 CVO™ Road King (FLHRSE), 2006-2023 Street Glide (FLHX), 2014-2023 Street Glide Special (FLHXS), 2015-2022 CVO™ Street Glide (FLHXSE), 2022-2023 Street Glide ST (FLHXST), 2009-2025 Tri Glide (FLHTCUTG), 2010-2011 Street Glide Trike (FLHXXX), 2020-2022 CVO™ Tri Glide (FLHTCUTGSE), 2015-2025 Freewheeler (FLRT), 2012-2016 Dyna Switchback (FLD) and 1984-2017 Softail models with OEM 7" headlamp bucket.

Yamaha®: 1999-2013 Road Star® models (except Warrior), Tour Deluxe, and MM) and 1998-2011 V-Star® 650/1100 Classic & Silverado

Additional wiring adapters (2120-0647 or 2001-1264 may be required for 2014-2025 models (sold separately). 2. High-Low-Halo adapter PN 2001-1397 to enable white halo light, also keeps low beam illuminated with high beam is activated (sold separately).

Installation:

1. Disconnect the vehicle battery negative [-] terminal.
2. Review detailed service manual for instructions on replacing factory headlamp.
3. Remove the factory headlamp from vehicle.
4. Before installing TruBEAM®, locate the vent on the rear of the unit and remove the white rubber cover so that the vent will function properly.
5. Connect the TruBEAM® headlamp to the existing factory H4 plug and re-install according to your vehicles manual.
6. LED Halo (Optional): Locate the white wire on the back of the TruBEAM® headlamp. Power this wire by attaching it to accessory/running light power or to the CDTB-HLA or H4-TOUR-ADAPTER (sold separately). See adapters instructions for installation.



Please read all Information below before Installation

Important: Due to the increased light output from this unit, it is recommended you take the vehicle to a dealer to have the headlamp properly adjusted. Weight and tire pressure can affect the position of the light.

Warning: To prevent possible electrical shock, disconnect the negative Battery terminal before installing this product.

Fitment Note: 2014-2024 Harley-Davidson® Electra Glide, Ultra, 2014-2025 Tri Glide models (including CVO™), 2014-2023 Street Glide (FLHX), Street Glide Special (FLHXS), 2014 Road King CVO™ and 2021-2025 Road King Special require **H4-TOUR-ADPT** for plug and play installation of TruBEAM® Headlamp. (see page 2)

Fitment Note: 2014-2022 Harley-Davidson® Road King (FLHR), 2017-2020 Road King Special (FLHRXS), and 2020-2025 Freewheeler (FLRT) require **CDTB-H42H9H11** adapter for plug and play installation of TruBEAM® Headlamp. (see page 2)

Fitment Note: Use Hi/Lo/Halo adapter **CDTB-HLA-1** to keep high and low beam on at same time on 2013-earlier Harley-Davidson® Touring models and 2014-2025 Touring models equipped with OEM LED Headlamp.

Fitment Note: To enable TruBEAM® halo ring and keep high and low beam on at same time on Softail® and Dyna® models with 7" headlamp use Hi/Lo/Halo adapter **CDTB-HLA-1**

Fitment Note: On some 1981-2013 Harley-Davidson® Touring fairings, the mounting ring hole may require trimming to accept the headlight. See Page 3.

Fitment Note: Not compatible with Harley Davidson® Garage Door Opener four-wire transmitter from Transmitter/Receiver Kits 91558-01 and 91558-01A or Transmitter Kit 91561-01.

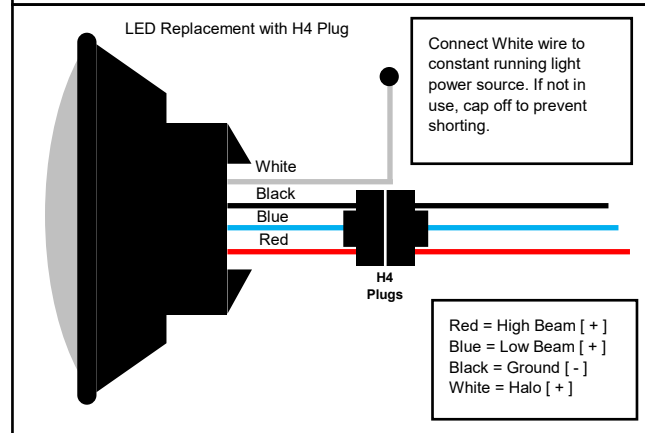

Installation Instructions - Page 2

7. Re-assemble headlamp per the instructions in detailed factory service manual. Make sure no wire or any components of the harness can be pinched during installation and that they will not be exposed to water spray, excessive heat or moving parts.
8. Re-connect vehicle battery negative [-] terminal.
9. Test function of head lamp for high beam and low beam function:
 - Stock function without adapter = When low beam is ON, high beam is OFF, when high beam is ON, low beam is OFF.
 - Function when Using CDTB-HLA = When low beam is ON, high beam is OFF. When high beam is ON, low beam is ON.
 - Halo Function = Halo will only work if connected running power is applied to the white wire. Function is optional.

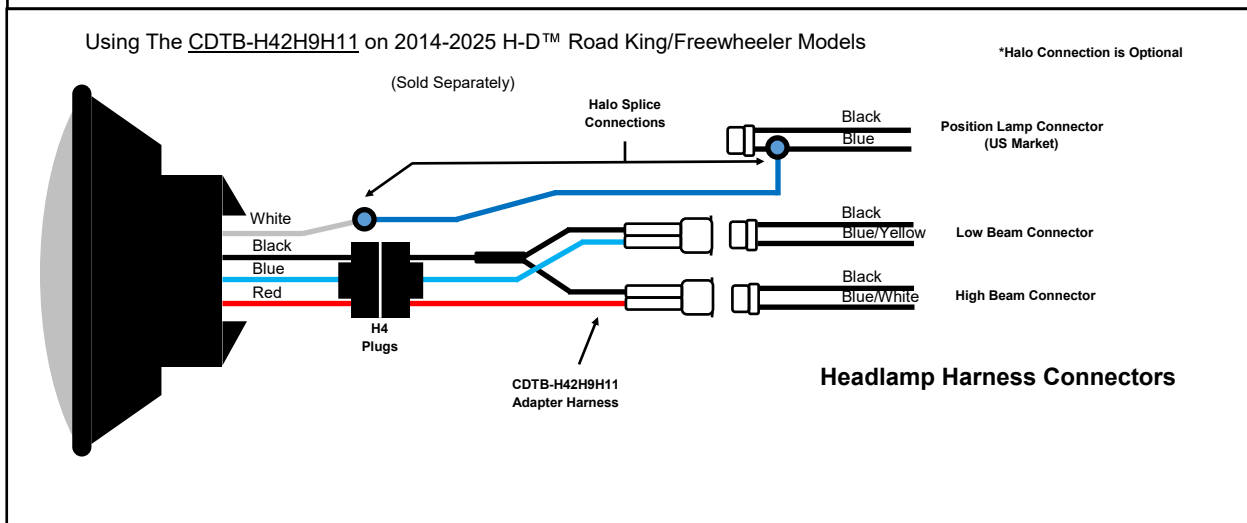
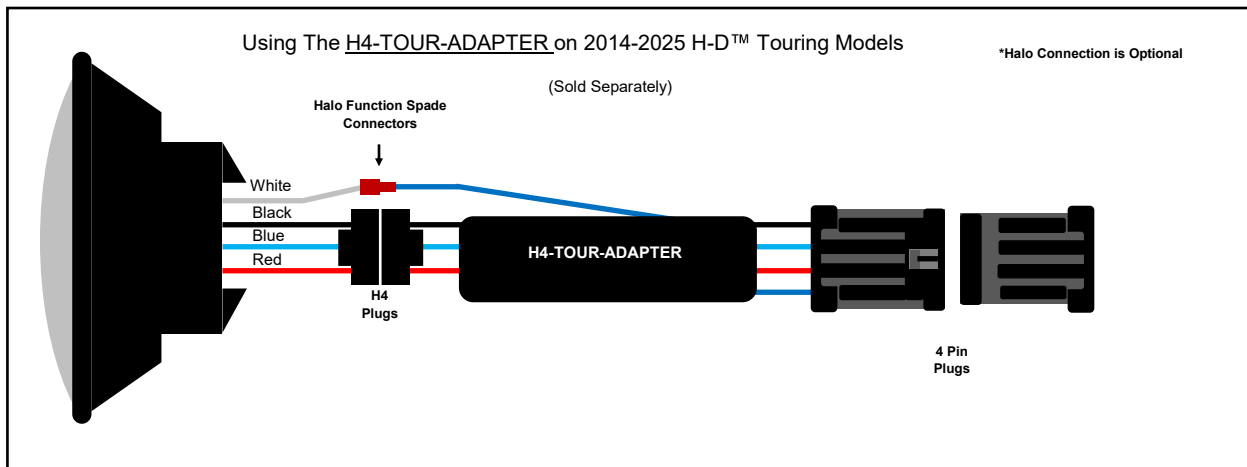

Installation Instructions - Page 3

Fitment Note - 1981-2013 HD Touring Models with Batwing Fairing

On some 1981-2013 HD Touring models with stock batwing fairing, the inner mounting ring hole may need to be enlarged for the new TruBEAM® headlight to fit properly. If you experience a gap between the light's mounting tabs and the mounting ring (see the photo to the right) you should remove the mounting ring assembly from the fairing, by removing the 5 screws.

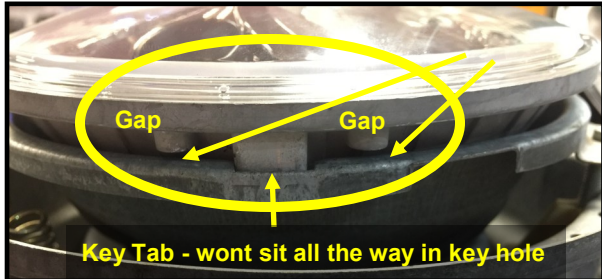

Next, using a file or preferably a Dremmel tool, remove about 1 mm of metal from the complete circumference of the opening. Test fit after the initial run to see where additional modification may need to be made. When there is no gap left in the Key opening in the mounting ring and the key tabs on the headlight fitment is good.

Remount the mounting ring to the Fairing and continue installation of headlight.

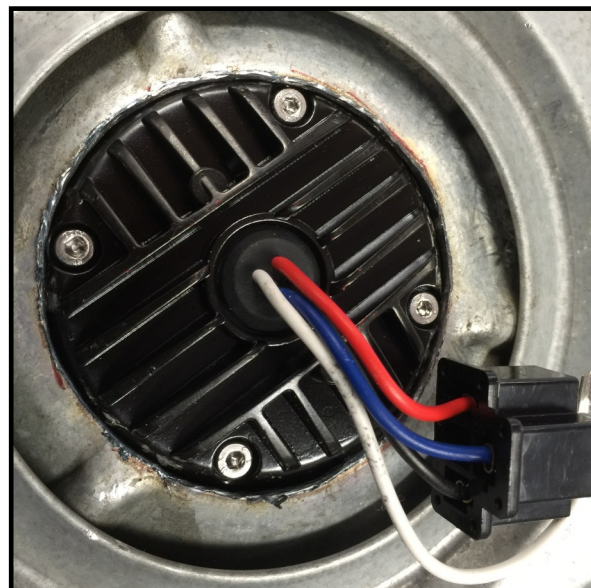

Everything to Light Up Your Ride®