



**CUSTOMLED**

## Custom Dynamics® Magic Strobes™ Brake Flasher Installation Instructions

We thank you for purchasing the Custom Dynamics® Magic Strobes™ Brake Light Flasher! Our products utilize the latest technology and high quality components to ensure you the most reliable service. We offer one of the best warranty programs in the industry and we back our products with excellent customer support, if you have questions before or during installation of this product please call Custom Dynamics® at 1(800) 382-1388.

**Part Number: MAGIC-STROBES-LTP2**

### Package Contents:

- Magic Strobes™ Brake Flasher (1)
- Instructions

Fits: 2014-2019 Electric Glide® Ultra Classic®, Electric Glide® Ultra Classic Lo, Electra Glide® Ultra Limited, Electric Glide® Ultra Classic Lo, Road Glide® Ultra, Road Glide® Ultra CVO™, Limited

### Installation:

1. Secure motorcycle on level surface.
2. Remove seat to gain access to tour pack wire harness.
3. Disconnect negative battery cable from the battery.
4. Find harness connector for Tour-Pak® located under the passenger's back rest on the Tour-Pak®. The wiring with the connectors forms a (Y), you want to use the connector at the bottom of the (Y) and not the two at the top. (See photo on back for reference)
5. Plug the Magic Strobes™ module, in-line, into the Tour-Pak® rear lighting harness bottom (Y) and into the bike's wiring harness.
6. Re-connect the battery's negative battery cable to the negative of the battery.

### Initial Setup and Operation:

7. Locate the two switches and rotary dial. Be sure the rotary dial is set to position 0. There is small arrow on the dial, this is the pointer that should now be at position 0. (see page 2)
8. Make sure switch 1 & 2 are in the ON position.
9. Select the desired strobe setting listed below with the power off. Always turn power off before changing settings.
10. Turn power on and test for function of the turn signals, running and brake signals with desired setting.
11. Switch 1 enables you to turn the strobe feature on/off on the rear turn signals of Tour-Pak®.
12. Switch 2 enables you the ability to turn on/off the center brake strobe signal.
13. To change pattern, turn bike off and change dial to desired pattern.
14. Locate a secure place for the Magic Strobes™ unit that will not interfere with the secure placement of the seat. Secure with the enclosed tie-wraps so that unit will not move.



# ATTENTION



Please read all Information below before Installation

**NOTE:** Confirm stock Tour-Pak® operation before purchasing. Corners of stock Tour-Pak LED must function as Run/Brake/ Turn for brake/flash patterns to affect these sections of the Tour-Pak®. BCM may need to be reprogrammed for left, center, and right sections of Tour-Pak® LED to flash/strobe when brake is applied.

**NOTE:** This module cannot be used with the Smart Triple Play® BCM.

**Important:** Dial and switches should be maneuvered by hand only. Do not use any tool such as a screwdriver that could damage waterproof covers.

**Important:** Module must be secured after installation. Find safe area away from any moving parts and out of the way of normal operation of the bike. Use the enclosed tie-wraps to secure. Custom Dynamics® is not liable for damage as a result of improperly securing or failing to secure the module.

**Important:** When Changing settings on Magic Strobes™ module, bike power should be OFF.

**Caution:** A stuck brake switch may cause this unit to overheat and fail. Unplug module immediately if this condition occurs.

**Note:** Although this device has been designed to significantly increase your braking visibility, flash/strobe patterns may not be street legal in your area. This Device is not DOT approved.

Questions? Call us at: 1 (800) 382-1388 M-TH 8:30AM-5:30PM / FR 9:30AM-5:30PM EST

# Installation Instructions - Page 2

## Tour-Pak Connector Location

For 2014-2019 models, the Harness connector for Tour-Pak is located under the pack along the back of passenger seat. The wiring with the connectors forms a (Y), you want to use the connector at the bottom of the (Y) and not the two at the top.

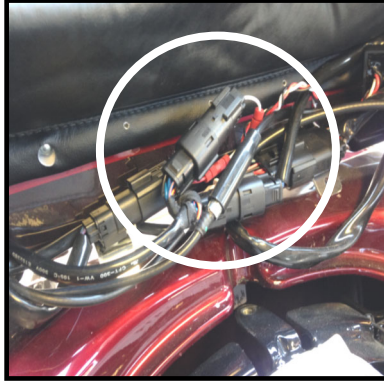

**Note:** Some 2016 models and all 2017-2019 models will not have a (y) configuration harness, there is only one 6 pin harness connector in this location, which is the correct Magic Strobes™ plug in location.

## Magic Strobes™ Functions

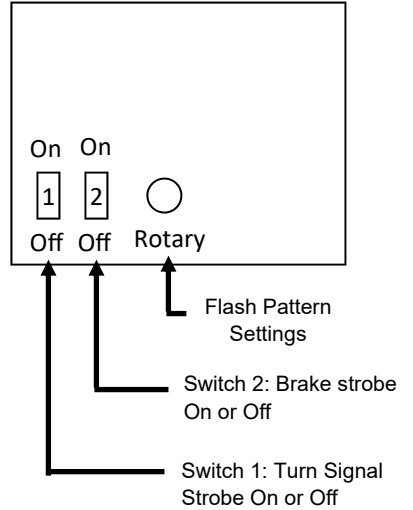

## Flash Pattern Information

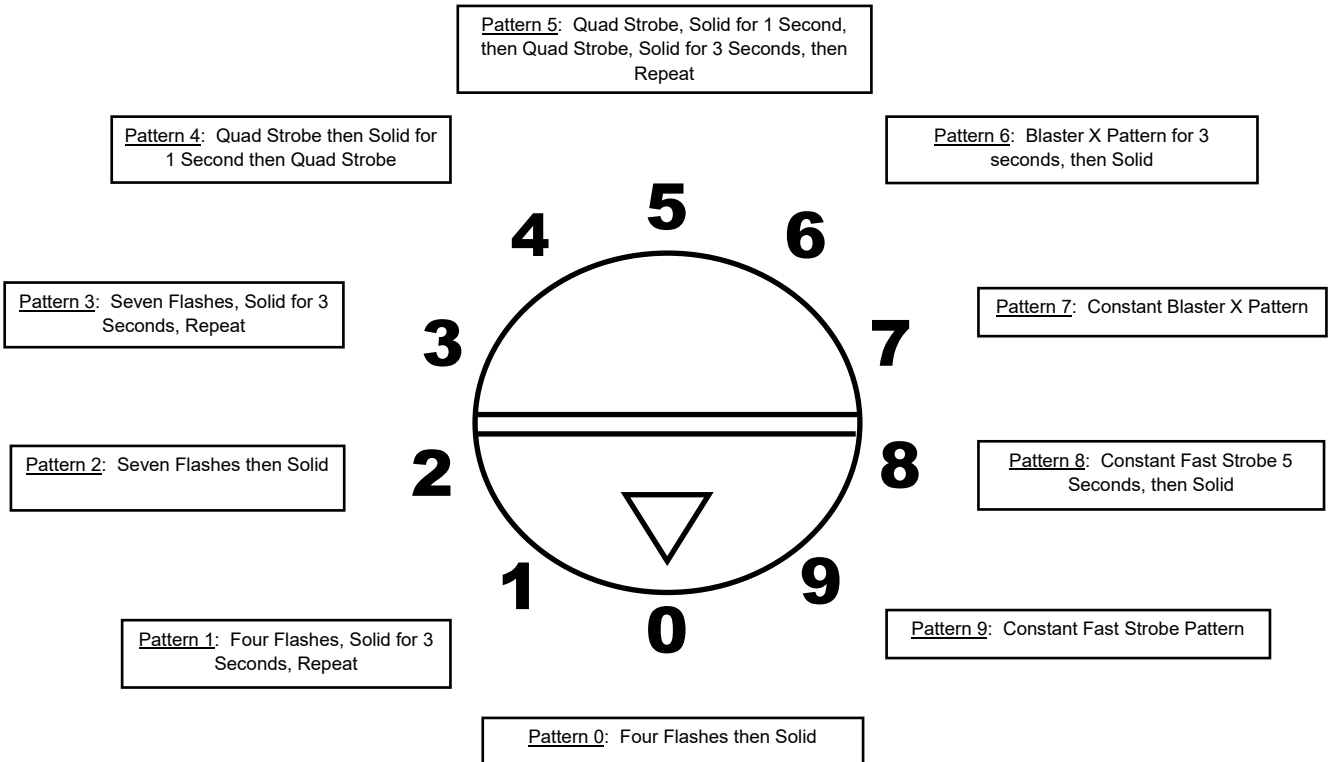

Questions? Call us at: 1 (800) 382-1388 M-TH 8:30AM-5:30PM / FR 9:30AM-5:30PM EST