



Custom Dynamics® Indian® Wiring Adapter Installation Instructions

We thank you for purchasing the Custom Dynamics® Indian® Wiring Adapter. Our products utilize the latest technology and high quality components to ensure you the most reliable service. We offer one of the best warranty programs in the industry and we back our products with excellent customer support, if you have questions before or during installation of this product please call Custom Dynamics® at 1(800) 382-1388.

Part Numbers: MPR-IND

Package Contents:

- MPR Indian® Wiring Adapter (1)
- Instructions (1)

Fits: 2020-2025 Indian® Challenger, Challenger Dark Horse, Challenger Limited 108 models, 2020-2024 Challenger Elite, 2022-2025 Pursuit Limited & Pursuit Dark Horse 108 models, 2015-2025 Chieftain, Chieftain Dark Horse, Chieftain Limited, 2025 Chieftain PowerPlus 108, Chieftain PowerPlus Limited 108, Chieftain PowerPlus Dark Horse 108, 2015-2025 Springfield, Springfield Dark Horse, Roadmaster, Roadmaster Dark Horse & Roadmaster Limited, 2015-2023 Chieftain Elite, 2015-2021 Chieftain Classic, Roadmaster Classic, 2015-2021 & 2024-2025 Roadmaster Elite, 2015-2020 Chief Classic & Chief Vintage, 2021 Vintage & Vintage Dark Horse, 2015-2024 Chief, Chief Dark Horse, 2022-2024 Chief Bobber, Chief Bobber Dark Horse, Super Chief & Super Chief Limited, and 2024 Sport Chief.



ATTENTION

Please read all Information below before Installation

Warning: Disconnect negative battery cable from battery; refer to owner's manual. Failure to do so may result in electrical shock, injury, or fire. Secure negative battery cable away from positive side of battery and all other positive voltage sources on motorcycle.

Safety First: Always wear appropriate safety gear including safety glasses when performing any electrical work. It is highly recommended that safety glasses be worn throughout this installation process. Be sure motorcycle is on level surface, secure and cool.

Important: This product is designed and intended for use as auxiliary lighting only. It is NOT intended to replace any original equipment lighting installed on the motorcycle and should not be used for that purpose. This product must be wired so that it does not interfere with any original equipment lighting.



Installation:

1. Remove all necessary parts and disconnect the negative battery cable from the battery.
2. Locate the rear fender lighting harness connectors under the seat.
3. Connect the Indian® Wiring Adapter inline with the rear fender lighting harness.
4. Connect wires as needed using the preinstalled Posi-Lock™ connector on the Indian® Wiring Adapter as follows:
 - **Black:** Constant ground.
 - **Blue:** Running.
 - **Red:** Brake.
 - **Orange:** Aux power.
 - **Brown:** Right side switched ground, right run/brake/turn (models without center taillight), right turn only (models with center taillight).
 - **Violet:** Left side switched ground, left run/brake/turn (models without center taillight), left turn only (models with center taillight).
5. Reconnect the negative battery cable to the battery and reinstall all necessary parts.
6. Test all rear lighting for proper operation.

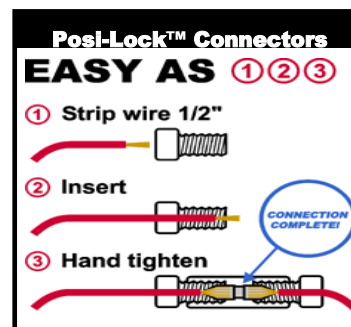

Questions? Email: info@CustomDynamics.com or Call us at: 1 (800) 382-1388 M-TH 8:30AM-5:30PM / FR 9:30AM-5:30PM EST