

Custom Dynamics® ProBEAM® LED Passing Lamps Installation Instructions



We thank you for purchasing the Custom Dynamics® ProBEAM® LED Passing Lamps. Our products utilize the latest technology and high quality components to ensure you the most reliable service. We offer one of the best warranty programs in the industry and we back our products with excellent customer support, if you have questions before or during installation of this product please call Custom Dynamics® at 1 (800) 382-1388.

Part Numbers: PB-45-B PB-45-C

Package Contents:

- ProBEAM® LED Passing Lamps (2)
- Instructions (1)

Fitment: 2024 Harley-Davidson® Ultra Limited (FLHTK) and Tri Glide Ultra (FLHTCUTG), 2023-earlier Electra Glide Classic (FLHTC), Electra Glide Classic CVO™ (FLHTCSE), Electra Glide Police (FLHTP), Ultra Classic (FLHTCU), Ultra Classic CVO™ (FLHTCUSE), Ultra Classic Low (FLHTCUL), Ultra Limited (FLHTK), Ultra Limited Low (FLHTKL), CVO™ Limited (FLHTKSE), Road King (FLHR), Road King Classic (FLHRC) & Road King Police (FLHP). 2008-earlier Electra Glide Standard (FLHT), 2009-2025 Tri Glide Ultra (FLHTCUTG) and 2020-2022 TriGlide CVO™ (FLHTCUTGSE), 2017-earlier Softail Deluxe (FLSTN), Deluxe CVO™ (FLSTNSE), Heritage (FLST), Heritage Classic (FLSTC), Heritage Springer (FLSTS) and Springer Classic (FLSTSC).

Note: 2004 and earlier models require adapter CDTB-PLA (sold separately).



ATTENTION

Please read all Information below before Installation

Warning: Disconnect negative battery cable from the battery; refer to owner's manual. Failure to do so may result in electrical shock, injury, or fire. Secure negative battery cable away from positive side of battery and all other positive voltage sources on motorcycle.

Important: Units must be properly aimed such that the beam pattern cut off line complies with applicable regulations.

Note: If installing with a visor trim ring or any trim ring that has foam, you must cut a space in the foam to allow the passing lamps to vent for moisture.



Installation:

1. Disconnect the negative battery cable from the battery.
2. Remove OEM passing lamps by removing the passing lamp trim ring and spacer and unplug from the OEM connectors.
3. Connect the new ProBEAM® LED Passing Lamps to the OEM connectors. Shown in **Figure 1**. **Note 2004 and earlier models will require adapter CDTB-PLA (sold separately) for plug and play.**

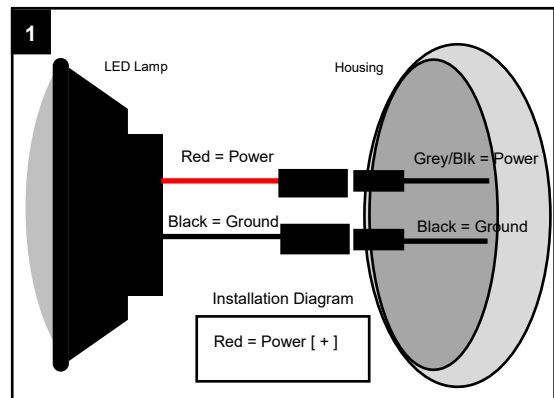

4. Reinstall passing lamps and passing lamp trim rings and spacers. Make sure no wires or any components of the harness or adapter can be crushed or pinched. **Note: If installing with a visor trim ring or any trim ring that have foam you must cut a space in the foam to allow the passing lamps to vent for moisture.**
5. Reconnect the negative battery cable to the battery.
6. Aim the ProBEAM® LED Passing Lamps if needed.
7. Test the new Custom Dynamics® ProBEAM® LED Passing Lamps for proper operation.

Questions? Email: info@CustomDynamics.com or Call us at: 1 (800) 382-1388 M-TH 8:30AM-5:30PM / FR 9:30AM-5:30PM EST