

## Custom Dynamics® ProBEAM® Fillerz® LED Inserts Installation Instructions



We thank you for purchasing the Custom Dynamics® ProBEAM® Fillerz® LED Inserts. Our products utilize the latest technology and high quality components to ensure you the most reliable service. We offer one of the best warranty programs in the industry and we back our products with excellent customer support, if you have questions before or during installation of this product please call Custom Dynamics® at 1(800) 382-1388.

**Part Numbers:** PB-FILL-R-B PB-FILL-S-B  
PB-FILL-R-C PB-FILL-S-C  
US Patent D814673, D824553, D846166  
China Patent ZL201730501975.7

### Package Contents:

- ProBEAM® Fillerz® LED Inserts (Pair)
- MPR-BCM-PLUG 6 Pin Adapter (1)
- 4" Cable Ties (8)
- Instructions (1)

**Fitment:** 2014-2023 Harley-Davidson® Ultra Limited (FLHTK), 2014-2019 Electra Glide Ultra Classic (FLHTCU), 2015-2016 Ultra Classic Lo (FLHTCUL), 2015-2018 Ultra Limited Lo (FLHTKL), 2014-2022 Road King (FLHR), 2016-2019 Road Glide Ultra (FLTRU), 2020-2023 Road Glide Limited (FLTRK), 2022-2023 Street Glide ST (FLHXST) and Road Glide ST (FLTRXST) and 2019-2022 Electra Glide Standard (FLHT).

Also fits 2014-2021 Harley-Davidson® CVO™ Limited (FLHTKSE), 2015-2016 CVO™ Road Glide Ultra (FLTRUSE) and 2022-2023 CVO™ Road Glide Limited (FLTRKSE) with **OEM Painted Panels (OEM P/N 90200763 and 90200764) removed.**

Also fits 2014-2023 Harley-Davidson® Street Glide (FLHX), Street Glide Special (FLHXS), Road Glide (FLTRX), Road Glide Special (FLTRXS) and 2017-2025 Road King Special (FLHRXS) with **Rear Fender Fascia (OEM P/N 59739-09) and TriBar Light (OEM P/N 59600008) removed.**



Please read all Information below before Installation

**Warning:** Disconnect negative battery cable from battery; refer to owner's manual. Failure to do so may result in electrical shock, injury, or fire. Secure negative battery cable away from positive side of battery and all other positive voltage sources on motorcycle.

**Safety First:** Always wear appropriate safety gear including safety glasses when performing any electrical work. It is highly recommended that safety glasses be worn throughout this installation process. Be sure vehicle is on level surface, secure and cool.

**Important:** This product is designed and intended for use as auxiliary lighting only. It is NOT intended to replace any original equipment lighting installed on the motorcycle and should not be used for that purpose. This product must be wired so that it does not interfere with any original equipment lighting.

**Note:** Functions as RUN/TURN on 2022-2022 Electra Glide Standard, 2014-2022 Road King Standard, 2014-2015 Limited CVO™, 2015-Road Glide Ultra CVO™, 2022-2023 Street Glide ST and 2022-2023 Road Glide ST. (**ProBEAM® Eclipze® required for RUN/BRAKE/TURN function. Sold separately.**)

**Important:** **CAN Bus Models** this product is BCM compliant, BCM Sync is required. **Non-CAN Bus Models** a SMART Signal Stabilizer® or Load Equalizer is required to ensure proper turn signal function and have the proper flash speed.



### Installation:

1. Remove the saddlebags to allow access to the saddlebag support brackets on the rear fender.
2. Remove the seat on the motorcycle to locate the 6 pin connector going to the rear fender. Plug MPR-BCM-PLUG Adapter inline with connector. Shown in **Figure 1**.

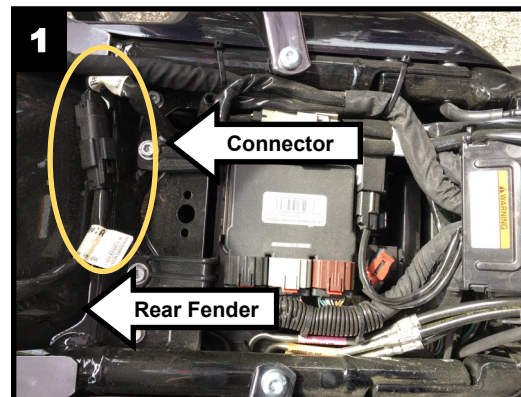

3. Clean the surface area of the saddlebag support bracket with de-natured alcohol and allow 1-2 minutes to dry.
4. Verify **Left** and **Right** ProBEAM® Fillerz® panels by looking on back at top will have an **L** or **R** stamped on it.
5. Remove the red protective film on the doubled sided tape from the back of the ProBEAM® Fillerz®. Line up the bottom edge of ProBEAM® Fillerz® with bottom of saddlebag support bracket. Push ProBEAM® Fillerz® into place until alignment tabs click. Apply pressure evenly over the ProBEAM® Fillerz® to ensure the tape is applied evenly. Shown in **Figure 2**.

Questions? Email: [info@CustomDynamics.com](mailto:info@CustomDynamics.com) or Call us at: 1 (800) 382-1388 M-TH 8:30AM-5:30PM / FR 9:30AM-5:30PM EST

## Installation Instructions - Page 2

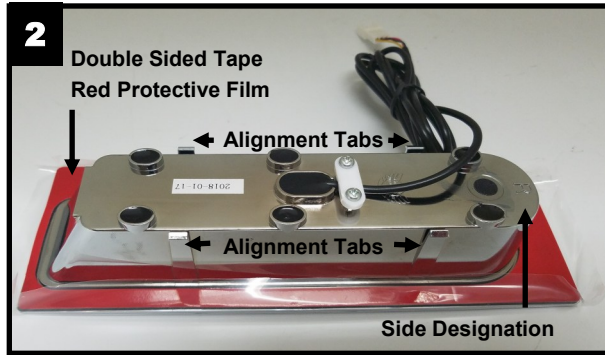

6. Route the wire from the ProBEAM® Fillerz® along the saddle-bag support brackets up to the MPR-BCM-PLUG location. Secure wires with Cable Ties to prevent the wires from being cut, frayed or pinched.
7. Connect the **Left** side ProBEAM® Fillerz® to the MPR-BCM-PLUG 3 pin connector that has the violet wire. Connect the **Right** side ProBEAM® Fillerz® to the 3 pin connector that has the brown wire.
8. Functions as **Run/Brake/Turn** on 2014-2023 Electra Glide Ultra Classic/ Lo, Ultra Limited/ Lo, Road Glide Ultra, 2020-2023 Road Glide Limited, 2016 Road Glide Ultra CVO™, 2016-2021 Limited CVO™. Functions as **Run/Turn** on 2019-2022 Electra Glde Standard, 2014-2022 Road King Standard, 2014-2015 Limited CVO™, 2015 Road Glide Ultra CVO™, 2022-2023 Street Glide ST and 2022-2023 Road Glide ST. **Note:** ProBEAM® Eclipse required for **Run/Brake/Turn** function (Sold Separately). **Note: See Installation Pages 3 and 4 for wire colors and functions.**
9. If dash indicators are Rapid Flashing perform a BCM Sync by turning the ignition **ON**. Turn 4 way hazards on and count 10 flashes and deactivate. Turn on 4 way hazards for another 10 flashes and deactivate. Turn ignition **OFF** then back **ON**, turn on 4 way hazards for 10 flashes and deactivate. **Note: After performing the BCM Sync, turn ignition ON and check dash indicators operation to make sure they are not Rapid Flashing.**
10. Test the Custom Dynamics® ProBEAM® Fillerz® for proper operation.

## Installation Instructions - Page 3

### MPR-BCM-PLUG Diagram With Fillerz® as Run-Brake and Turn using PB-EPZ (sold separately)

2019-2022 Electra Glide® Standard (FLHT), 2014-2022 Road King® Standard, 2014-2015 Limited CVO™, 2015 Road Glide Ultra CVO™, 2022-2023 Street Glide ST and 2022-2023 Road Glide ST Run-Brake-Turn \*PB-EPZ required for run, brake, turn function (sold separately).

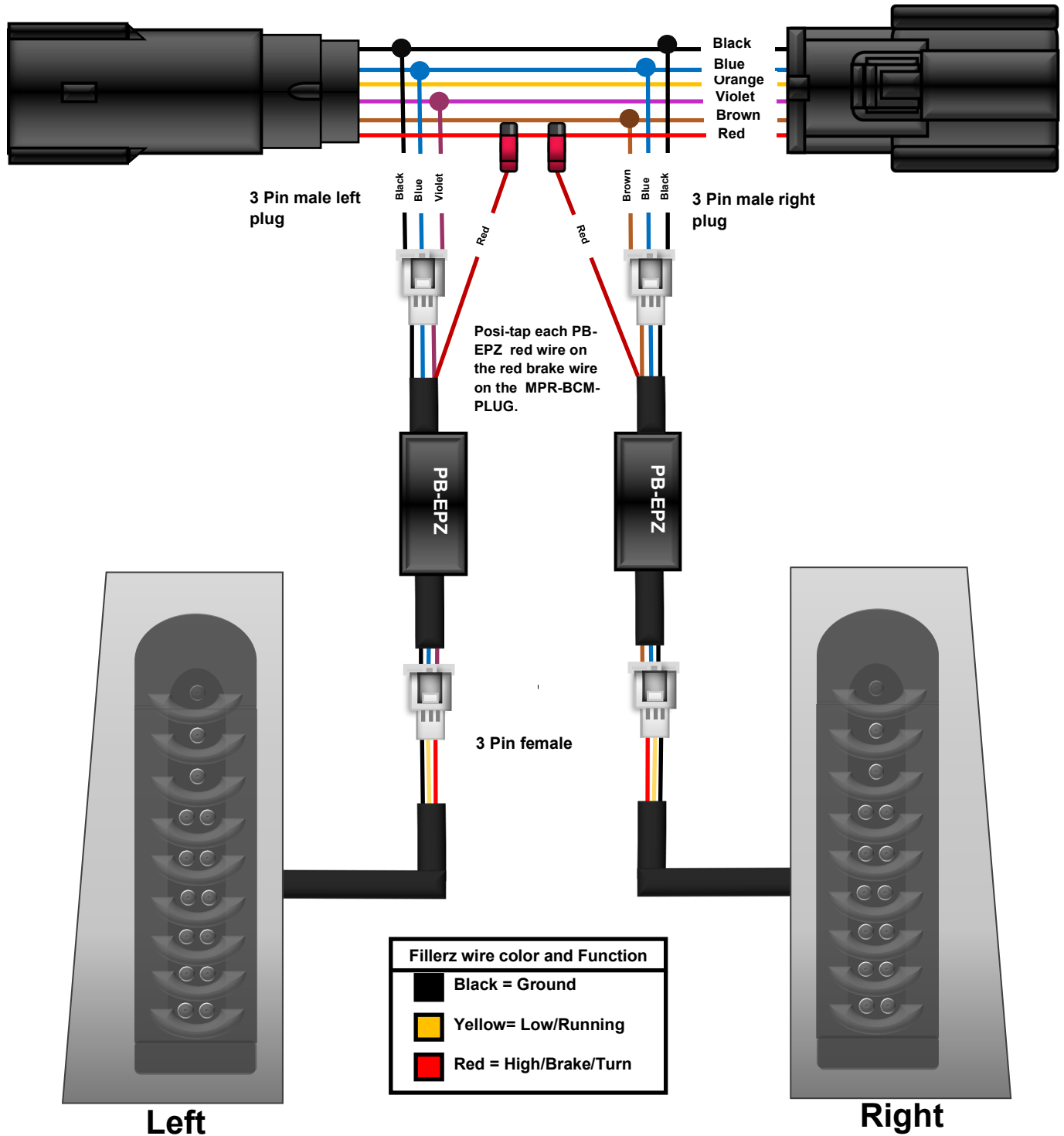

**Notice:** This product is designed and intended for motorcycle auxiliary lighting use only. This product is **NOT** intended to replace any OEM lighting installed on the motorcycle and should not be used for that purpose. This product must be wired in such a manner that it does not interfere with any OEM lighting.

# Installation Instructions - Page 4

## Road King, Electra Glide Standard

Run/Turn (Original Configuration) MPR-BCM-PLUG

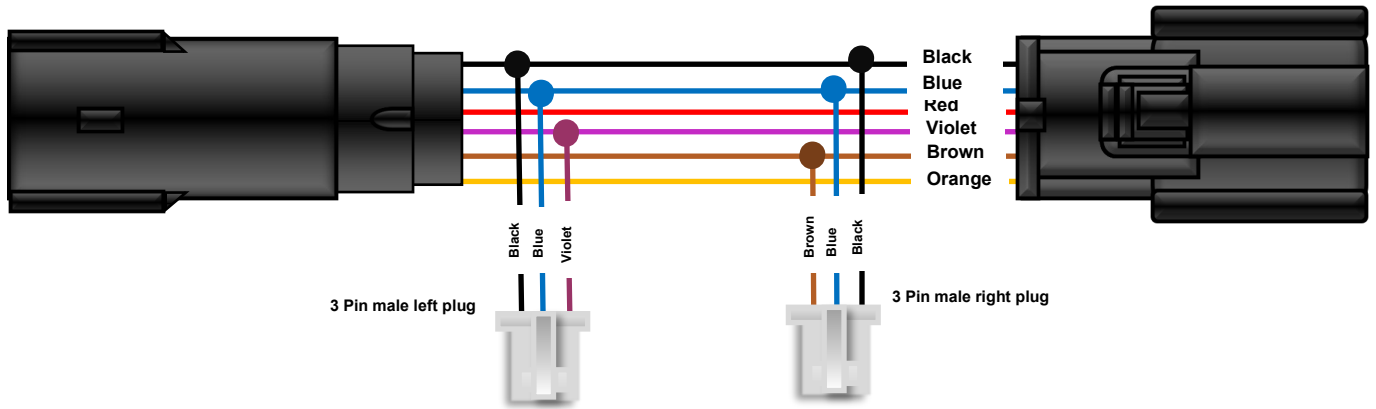

## Run-Brake Modification MPR-BCM-PLUG

\*Violet and Brown Wires going from the 3 Pin Connector to the Y Harness must be cut and moved to the red wire of the Y Harness.

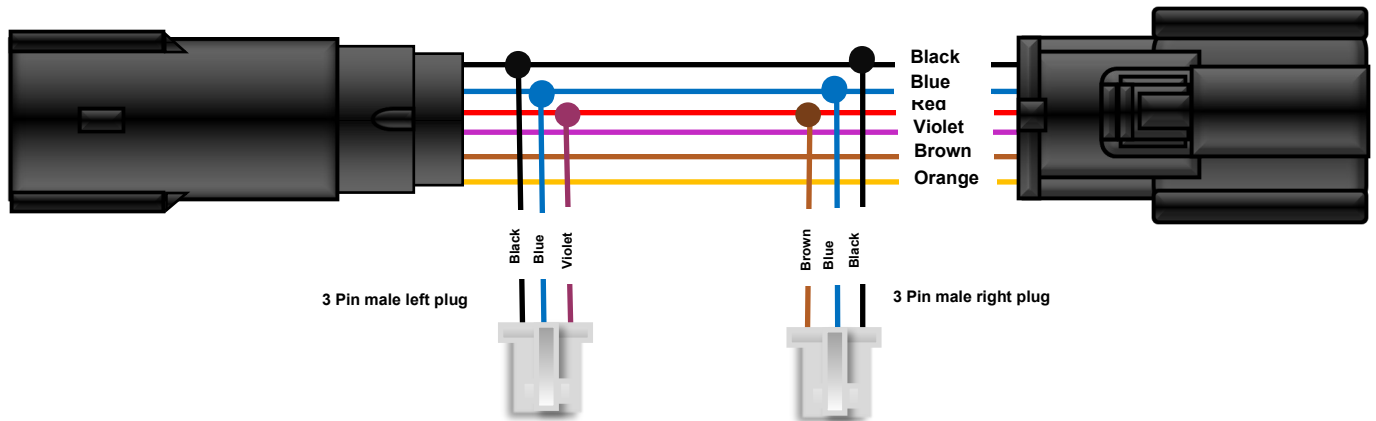

### MPR-BCM-PLUG wire color and function

- Black- Ground
- Blue- Running
- Red- Brake
- Violet- Left Turn/Brake
- Brown- Right Turn/Brake
- Orange- Auxiliary Power