



Custom Dynamics® Plug and Play Plasma Rod™ Adapter Installation Instructions

We thank you for purchasing the Custom Dynamics® Plug and Play Plasma Rod™ Adapter. Our products utilize the latest technology and high quality components to ensure you the most reliable service. We offer one of the best warranty programs in the industry and we back our products with excellent customer support, if you have

Part Numbers: PR-MPR-BCM

Package Contents:

- BCM Plasma Rod™ Adapter w/ Plugs (1)

Fits: Functions as **Run, Brake & Turn Signal** on 2014-2021 Harley-Davidson® Street Glide (FLHX), Street Glide Special (FLHXS), Road Glide (FLTRX), Road Glide Special (FLTRXS), Road Glide Limited (FLTRK), Road Glide Ultra (FLTRU), Ultra Classic (FLHTCU), Ultra Classic Low (FLHTCUL), Ultra Limited (FLHTK), Ultra Limited Low (FLHTKL), Road King Special (FLHRS), 2016 Road Glide Ultra CVO™ and 2016-2021 Ultra Limited CVO (FLHTKSE) with PR-PLUG-R Plug and Play Red Plasma Rods™ (Sold Separately).

Functions as **Run/Turn** on 2014-2021 Harley-Davidson® Road King® (FLHR), 2014 Road King® CVO™ (FLTRXSE), 2014-2021 Street Glide® CVO™ (FLHXSE), 2018-2021 Road Glide® CVO™ (FLTRXSE), 2015 Road Glide® Ultra CVO™ (FLTRUSE), 2014-2015 Ultra Limited CVO™, 2014-2018 Electra Glide® Police (FLHTP) and 2019-2021 Electra Glide® Standard (FLHT) with PR-PLUG-R Plug and Play Red Plasma Rods™ (Sold Separately).

Refer to page 2 & 3 for diagrams on alternative functions and wiring.



Installation:

1. Secure motorcycle on level surface. Remove seat and disconnect negative battery cable from the battery.
2. Locate and unplug the rear lighting harness connector to the rear fender.
3. Plug the provided BCM Plasma Rod™ Adapter, in-line, into the rear lighting harness and into the bike's main wiring harness.
4. Connect the Plug and Play Plasma Rods™ (Sold Separately) to the installed BCM Plasma Rod™ Adapter. Connect Left Plasma Rod™ to the 3 pin connector of the BCM Plasma Rod™ Adapter with the Purple wire. Connect Right Plasma Rod™ to the 3 pin connector of the BCM Plasma Rod™ Adapter with the Brown wire.
5. Secure wires under the seat to prevent the wires from becoming cut, frayed, or pinched.
6. Reconnect the negative battery cable to the battery and reinstall the seat.
7. Test operation of all lighting before riding.



Please read all Information below before Installation

Warning: Disconnect negative battery cable from battery; refer to owner's manual. Failure to do so may result in electrical shock, injury, or fire. Secure negative battery cable away from positive side of battery and all other positive voltage sources on vehicle.

Safety First: Always wear appropriate safety gear including safety glasses when performing any electrical work. It is highly recommended that safety glasses be worn throughout this installation process. Be sure vehicle is on level surface, secure and cool.

Important: This product is designed and intended for use as auxiliary lighting only. It is NOT intended to replace any original equipment lighting installed on the vehicle and should not be used for that purpose. This product must be wired so that it does not interfere with any original equipment lighting.

Note: The BCM Plasma Rod™ Adapter must be plugged into the output (behind) any Smart Signal Stabilizer™/load equalizer or any brake strobe modules.

Note: Plasma Rods™ are designed to operate as **Run/Brake**. However, lights can be configured to operate as Run/Turn or Run/Brake/Turn. See page 2 & 3 for alternative configurations.

Questions? Call us at: 1 (800) 382-1388 M-TH 8:30AM-5:30PM / FR 9:30AM-

Installation Instructions - Page 2

Run-Brake Modification

For 2014 CVO™ Road King, 2015-2021 CVO™ Street Glide, 2018-2021 CVO™ Road Glide, 2014-2021 Road King® Standard, 2014-2015 Limited CVO™ & 2015 Road Glide Ultra CVO™

*Purple and Brown Wires going from the 3 Pin Connectors to the BCM Plasma Rod™ Adapter must be cut and moved from the Purple and Brown to the Red Connections can easily be made using Posi-Tap™ connectors (Sold Separately)

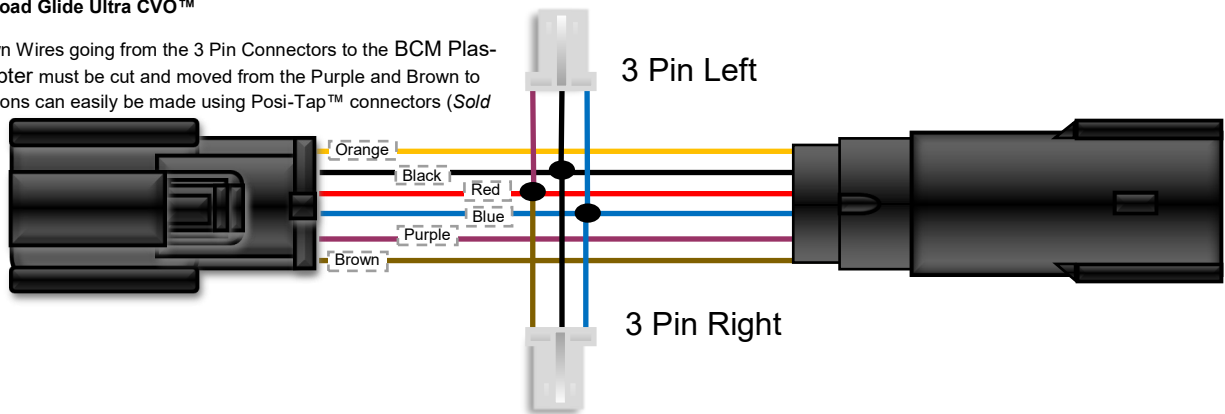

Run-Brake-Turn Modification

For 2014-2021 Road King® Standard, 2014-2015 Limited CVO™ & 2015 Road Glide Ultra CVO™ .

Plug-N-Play with SMART Triple Play® accessory plugs

*SMART Triple Play® with accessory plugs required. The provided BCM Plasma Rod™ Adapter **will not** be used. The two 3 pin connectors that extend from the output side of the Smart Triple Play® module allow for plug and play installation. Simply plug in the left side (purple) and right side (brown) male connectors from the Smart Triple Play® to the corresponding female connectors on the product.

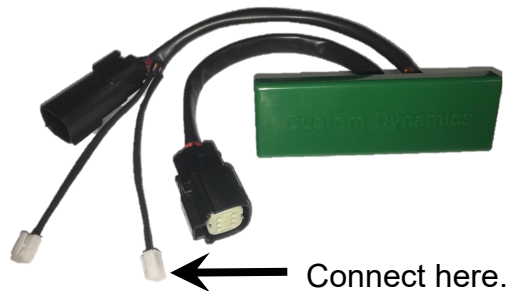
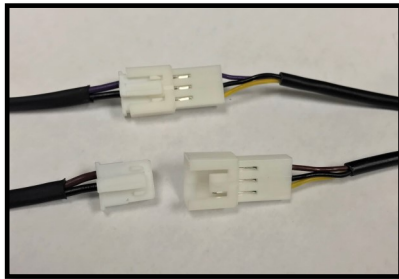

SMART Triple Play® without accessory plugs

*SMART Triple Play® without accessory plugs required. On the BCM Plasma Rod™ Adapter, the Blue wires going to both three pin connectors must be cut and capped off. BCM Y Harness Adapter must be installed on output side of SMART Triple Play®

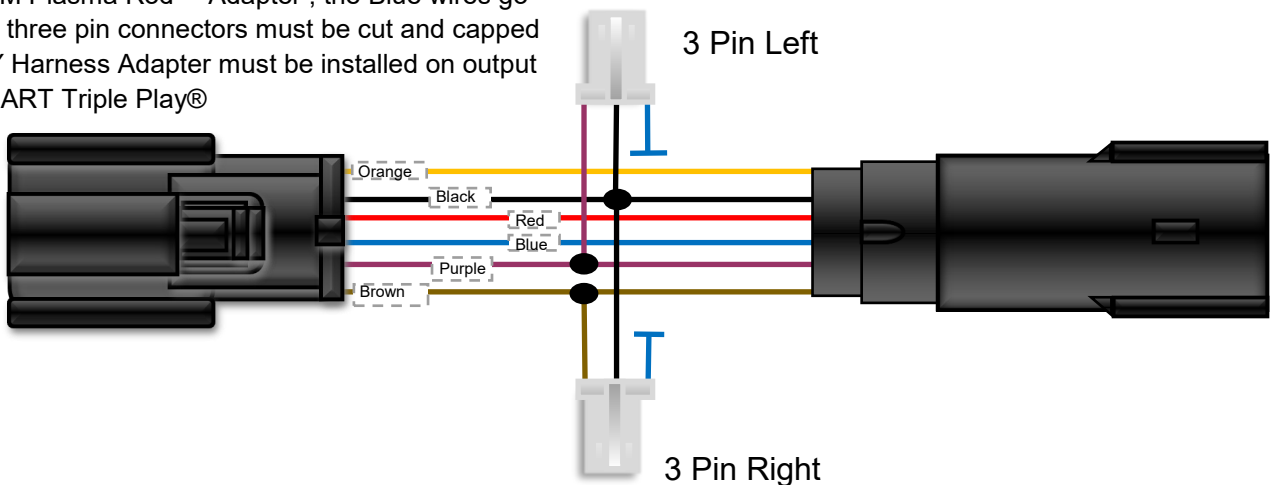

Questions? Call us at: 1 (800) 382-1388 M-TH 8:30AM-5:30PM / FR 9:30AM-5:30PM EST

Installation Instructions - Page 3

Run-Brake-Turn modification with GEN-SMART-TPU-14CVO

2014 CVO™ Road King, 2015-2021 CVO™ Street Glide & 2018-2021 CVO™ Road Glide

SMART Triple Play® (**GEN-SMART-TPU-14CVO**) required. On the BCM Plasma Rod™ Adapter, the Blue wires going to the two 3 pin connectors must be cut and capped off.

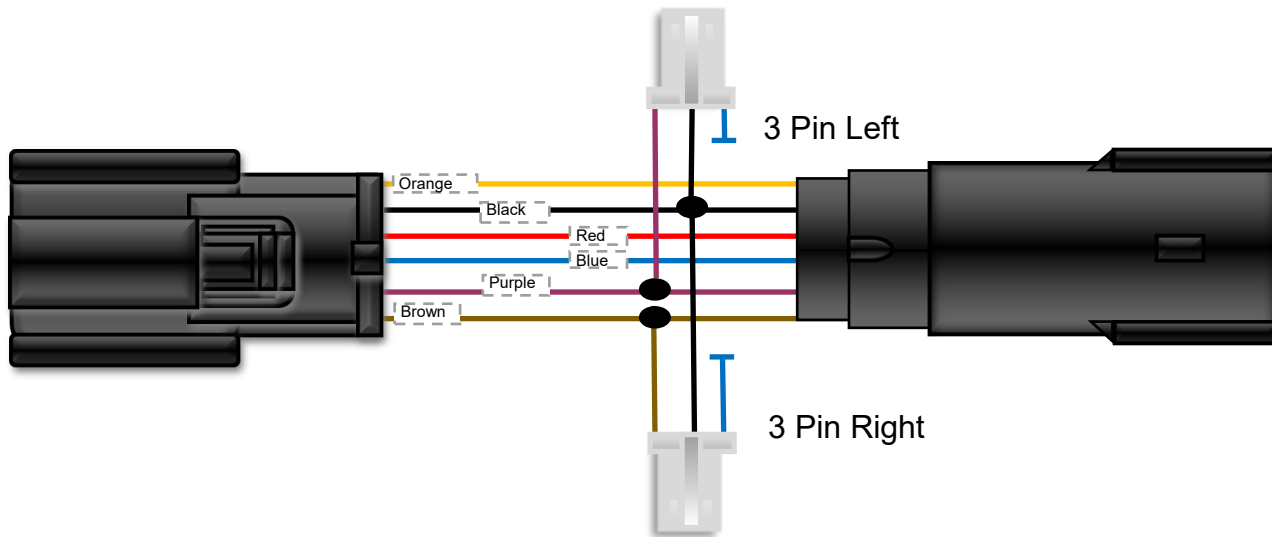

Questions? Call us at: 1 (800) 382-1388 M-TH 8:30AM-5:30PM / FR 9:30AM-5:30PM EST



Custom Dynamics® Plug and Play Plasma Rod™ Adapter Installation Instructions

We thank you for purchasing the Custom Dynamics® Plug and Play Plasma Rod™ Adapter. Our products utilize the latest technology and high quality components to ensure you the most reliable service. We offer one of the best warranty programs in the industry and we back our products with excellent customer support, if you have questions before or during installation of this product please call Custom Dynamics® at 1(800) 382-1388.

Part Numbers: PR-MPR-HD

Package Contents:

- HD Plasma Rod™ Adapter w/ Plugs (1)

Fits: 1996-2017 Softails (except Breakout, Slim/Slim-S & Blackline), 1997-2017 Dynas (except FXDB & FXDWG), 1997-2013 Touring (except Street Glide & Road Glide Custom), and 1999-2003 Sportsters, 2010-2013 HD Trikes; 2011-2013 Road Glide Ultra with PR-PLUG-R Plug and Play Red Plasma Rods™ (Sold Separately).

Note: Plasma Rods™ are designed to operate as **Run/Brake**. However, lights can be configured to operate as Run/Turn or Run/Brake/Turn. See page 2 for alternative configurations.



Please read all Information below before Installation

Warning: Disconnect negative battery cable from battery; refer to owner's manual. Failure to do so may result in electrical shock, injury, or fire. Secure negative battery cable away from positive side of battery and all other positive voltage sources on vehicle.

Safety First: Always wear appropriate safety gear including safety glasses when performing any electrical work. It is highly recommended that safety glasses be worn throughout this installation process. Be sure vehicle is on level surface, secure and cool.

Important: This product is designed and intended for use as auxiliary lighting only. It is NOT intended to replace any original equipment lighting installed on the vehicle and should not be used for that purpose. This product must be wired so that it does not interfere with any original equipment lighting.

Note: Lights are designed to operate as **Run/Brake**. However, lights can be configured to operate as Run/Turn or Run/Brake/Turn. See Page 2 for alternative configurations.

Installation:

1. Secure motorcycle on level surface. Remove seat and disconnect negative battery cable from the battery.
2. Locate and unplug the rear lighting harness connector to the rear fender.
3. Plug the provided HD Plasma Rod™ Adapter, in-line, into the rear lighting harness and into the bike's main wiring harness.
4. Connect the Plug and Play Plasma Rods™ (Sold Separately) to the installed HD Plasma Rod™ Adapter. Connect Left Plasma Rod™ to the 3 pin connector of the HD Plasma Rod™ Adapter with the Purple wire. Connect Right Plasma Rod™ to the 3 pin connector of the HD Plasma Rod™ Adapter with the Brown wire.
5. Secure wires under the seat to prevent the wires from becoming cut, frayed, or pinched.
6. Reconnect the negative battery cable to the battery and reinstall the seat.
7. Test operation of all lighting before riding.

Questions? Call us at: 1 (800) 382-1388 M-TH 8:30AM-5:30PM / FR 9:30AM-5:30PM EST

Installation Instructions - Page 2.

Run-Turn Configuration

*On the HD Plasma Rod™ Adapter, the Brown wire of the 3 pin connector should be cut where it meets the Red wire and relocated to Brown wire. The Purple wire of the 3 pin connector should be cut where it meets the Red wire and relocated to Purple connector wire. Connections can easily be made using Posi-Tap™ connectors (*Sold Separately*) See photo below for reference.

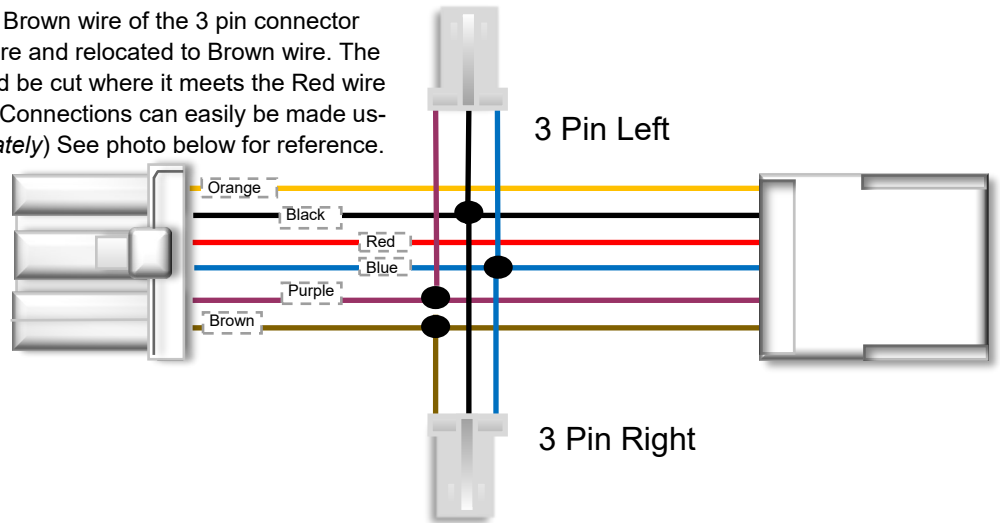

Run-Brake-Turn Plug-N-Play with SMART Triple Play®

*SMART Triple Play® with accessory plugs required. The provided Plasma Rod™ harness **will not** be used. The two 3 pin connectors that extend from the output side of the Smart Triple Play® module allow for plug and play installation. Simply plug in the left side (purple) and right side (brown) male connectors from the Smart Triple Play® to the corresponding female connectors on the product.

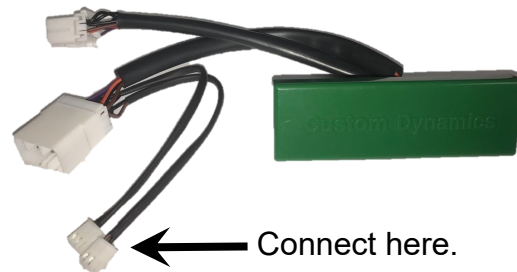
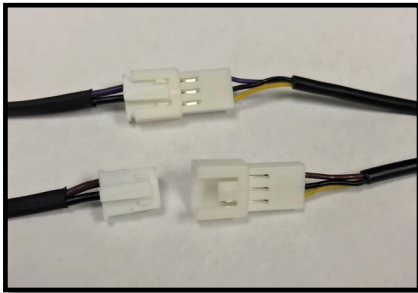

Run-Brake-Turn With Modification *SMART Triple Play®

without accessory plugs required. On the HD Plasma Rod™ Adapter, the Blue wires going to the two 3 pin connectors must be cut and capped off. Brown wire of the 3 pin connector should be cut where it meets the Red wire and relocated to Brown harness adapter wire. The Purple wire of the 3 pin connector should be cut where it meets the Red wire and relocated to Purple harness adapter wire. Connections can easily be made using Posi-Tap™ connectors (*Sold Separately*).

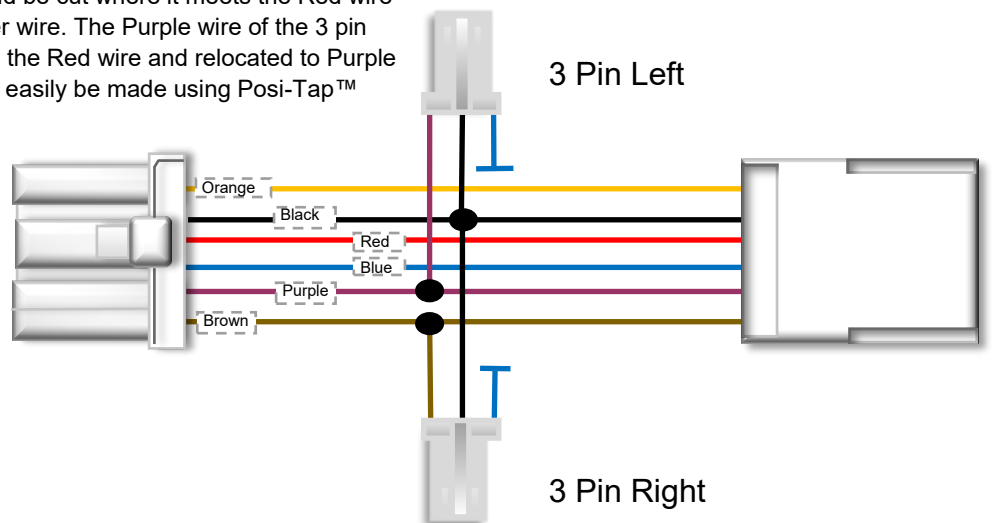

Questions? Call us at: 1 (800) 382-1388 M-TH 8:30AM-5:30PM / FR 9:30AM-5:30PM EST



Custom Dynamics® Plug and Play Plasma Rod™ Adapter Installation Instructions

We thank you for purchasing the Custom Dynamics® Plug and Play Plasma Rod™ Adapter. Our products utilize the latest technology and high quality components to ensure you the most reliable service. We offer one of the best warranty programs in the industry and we back our products with excellent customer support, if you have questions before or during installation of this product please call Custom Dynamics® at 1(800) 382-1388.

Part Numbers: PR-MPR-SS6

Package Contents:

- SS6 Plasma Rod™ Adapter w/ Plugs (1)

Fits: 2010-2013 Harley-Davidson® Street Glide (FLHX) and Road Glide Custom (FLTRX) with PR-PLUG-R Plug and Play Red Plasma Rods™ (Sold Separately).

Does not fit CVO™ models.

Note: Plasma Rod™ are designed to operate as Run/Brake. However, lights can be configured to operate as Run/Turn or Run/Brake/Turn. **See page 2 & 3 for alternative configurations.**



Installation:

1. Secure motorcycle on level surface. Remove seat and disconnect negative battery cable from the battery.
2. Remove the left side cover, locate and unplug the rear lighting connector to the rear fender.
3. Plug the provided SS6 Plasma Rod™ Adapter, in-line, into the rear lighting harness and into the bike's main wiring harness.
4. Connect the Plug and Play Plasma Rods™ (Sold Separately) to the installed SS6 Plasma Rod™ Adapter. Connect Left Plasma Rod™ to the 3 pin connector of the SS6 Plasma Rod™ Adapter with the Purple wire. Connect Right Plasma Rod™ to the 3 pin connector of the SS6 Plasma Rod™ Adapter with the Brown wire.
5. Secure wires under the seat and behind the Left side cover to prevent the wires from becoming cut, frayed, or pinched.
6. Reconnect the negative battery cable to the battery and reinstall the seat.
7. Test operation of all lighting before riding.



Please read all Information below before Installation

Warning: Disconnect negative battery cable from battery; refer to owner's manual. Failure to do so may result in electrical shock, injury, or fire. Secure negative battery cable away from positive side of battery and all other positive voltage sources on vehicle.

Safety First: Always wear appropriate safety gear including safety glasses when performing any electrical work. It is highly recommended that safety glasses be worn throughout this installation process. Be sure vehicle is on level surface, secure and cool.

Important: This product is designed and intended for use as auxiliary lighting only. It is NOT intended to replace any original equipment lighting installed on the vehicle and should not be used for that purpose. This product must be wired so that it does not interfere with any original equipment lighting.

Note: The SS6 Plasma Rod™ Adapter must be plugged into the output (behind) any Smart Signal Stabilizer™/load equalizer or any brake strobe modules.

Note: Plasma Rods™ are designed to operate as **Run/Brake**. However, lights can be configured to operate as Run/Turn or Run/Brake/Turn. See page 2 and 3 for alternative configurations.

Questions? Call us at: 1 (800) 382-1388 M-TH 8:30AM-5:30PM / FR 9:30AM-5:30PM EST

Run, Brake and Turn function Requires P/N: PB-TRI-2

Custom Dynamics® dual intensity LED TriBar with SMART Triple Play®

Run-Brake-Turn Plug-N-Play with SMART Triple Play® Included with PB-TRI-2

***Requires** Custom Dynamics® dual intensity LED TriBar with SMART Triple Play® **with** accessory plugs. The provided SS6 Plasma Rod™ Adapter **will not** be used. The two 3 pin connectors that extend from the output side of the Smart Triple Play® module allow for plug and play installation. Simply plug in the left side (purple) and right side (brown) male connectors from the Smart Triple Play® to the corresponding female connectors on the product.

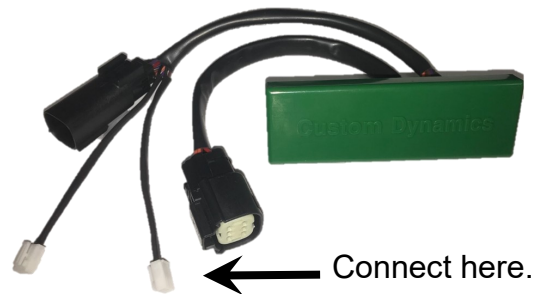
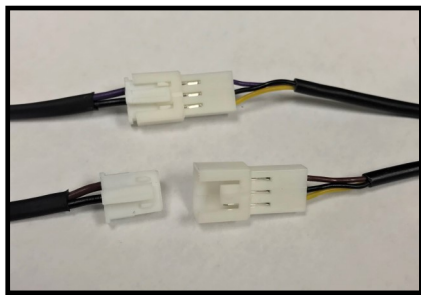

Run-Brake-Turn With Modification

***Requires** Custom Dynamics® dual intensity LED TriBar with SMART Triple Play® **without** accessory plugs required. On the SS6 Plasma Rod™ Adapter, the Blue wires going to the two 3 pin connectors must be cut and capped off. Brown wire of the 3 pin connector should be cut where it meets the Red wire and relocated to Brown harness adapter wire. The Purple wire of the 3 pin connector should be cut where it meets the Red wire and relocated to Purple harness adapter wire. Connections can easily be made using Posi-Tap™ connectors (*Sold Separately*)

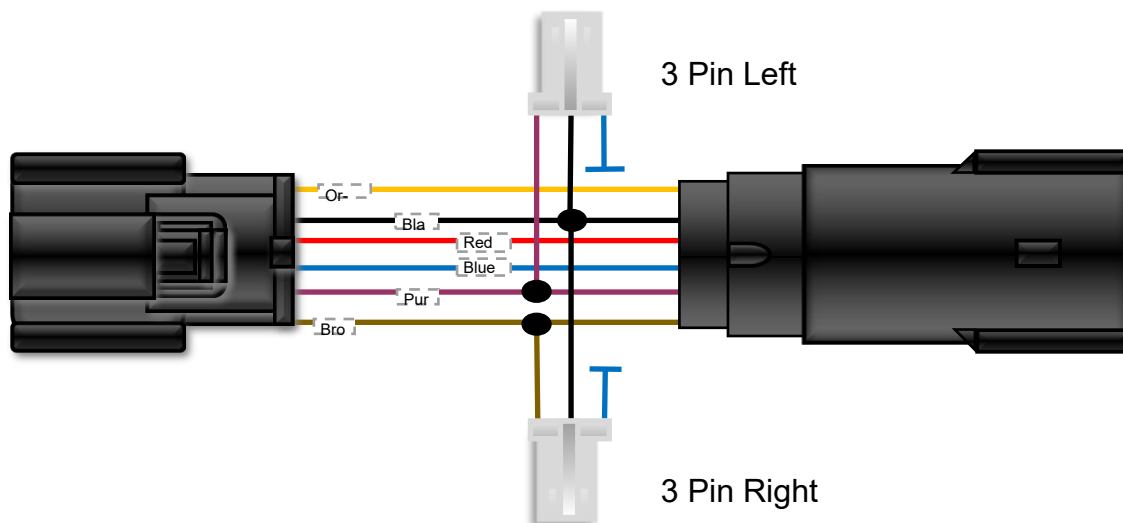

Run-Turn Configuration

*On the SS6 Plasma Rod™ Adapter, , the Brown wire of the 3 pin connector should be cut where it meets the Red wire and relocated to Brown wire. The Purple wire of the 3 pin connector should be cut where it meets the Red wire and relocated to Purple connector wire. Connections can easily be made using Posi-Tap™ connectors (Sold Separately) See photo below for reference.

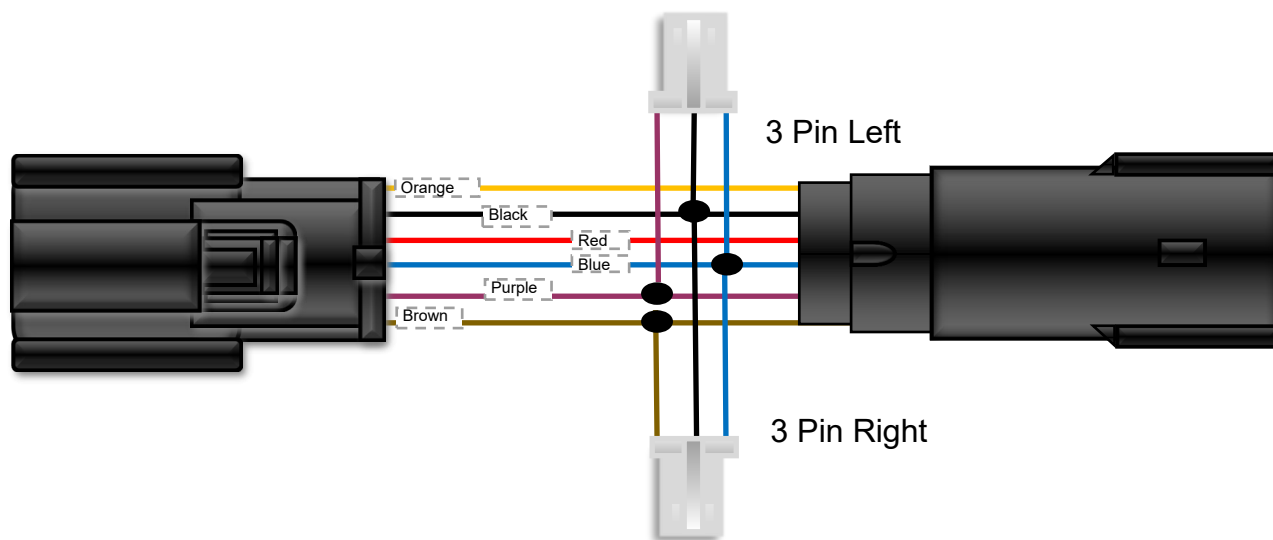



Custom Dynamics® Plug and Play Plasma Rod™ Adapter Installation Instructions

We thank you for purchasing the Custom Dynamics® Plug and Play Plasma Rod™ Adapter. Our products utilize the latest technology and high quality components to ensure you the most reliable service. We offer one of the best warranty programs in the industry and we back our products with excellent customer support, if you have questions before or during installation of this product please call Custom Dynamics® at 1(800) 382-1388.

Part Numbers: PR-MPR-SS8

Package Contents:

- SS8 Plasma Rod™ Adapter w/ Plugs (1)

Fits: 2009-2013 Harley-Davidson® CVO™ Street Glide (FLHXSE) and CVO™ Road Glide Custom (FLTRXSE), 2013 CVO™ Road King (FLHRSE) with PR-PLUG-R Plug and Play Red Plasma Rods™ (Sold Separately).

Note: Plasma Rods™ are designed to operate as Run/Brake. However, lights can be configured to operate as Run/Turn or Run/Brake/Turn. **See page 2 for alternative configurations.**



Installation:

1. Secure motorcycle on level surface. Remove seat and disconnect negative battery cable from the battery.
2. Locate and unplug the rear lighting harness connector to the rear fender.
3. Plug the provided SS8 Plasma Rod™ Adapter, in-line, into the rear lighting harness and into the bike's main wiring harness.
4. Connect the Plug and Play Plasma Rods™ (Sold Separately) to the installed SS8 Plasma Rod™ Adapter. Connect Left Plasma Rod™ to the 3 pin connector of the SS8 Plasma Rod™ Adapter with the Purple wire. Connect Right Plasma Rod™ to the 3 pin connector of the SS8 Plasma Rod™ Adapter with the Brown wire.
5. Secure wires under the seat to prevent the wires from becoming cut, frayed, or pinched.
6. Reconnect the negative battery cable to the battery and reinstall the seat.
7. Test operation of all lighting before riding.



Please read all Information below before Installation

Warning: Disconnect negative battery cable from battery; refer to owner's manual. Failure to do so may result in electrical shock, injury, or fire. Secure negative battery cable away from positive side of battery and all other positive voltage sources on vehicle.

Safety First: Always wear appropriate safety gear including safety glasses when performing any electrical work. It is highly recommended that safety glasses be worn throughout this installation process. Be sure vehicle is on level surface, secure and cool.

Important: This product is designed and intended for use as auxiliary lighting only. It is NOT intended to replace any original equipment lighting installed on the vehicle and should not be used for that purpose. This product must be wired so that it does not interfere with any original equipment lighting.

Note: The SS8 Plasma Rod™ Adapter must be plugged into the output (behind) any Smart Signal Stabilizer™/load equalizer or any brake strobe modules.

Note: Plasma Rods™ are designed to operate as **Run/Brake**. However, lights can be configured to operate as Run/Turn or Run/Brake/Turn. **See page 2 for alternative configurations.**

Questions? Call us at: 1 (800) 382-1388 M-TH 8:30AM-5:30PM / FR 9:30AM-5:30PM EST

Installation Instructions - Page 2

Run-Brake-Turn modification with GEN-SMART-TPU-SS8

2010-2012 Street Glide® CVO™, 2009 Road Glide® CVO™, 2012-2013 Road Glide® Custom CVO™, 2013 Road King® CVO™

*SMART Triple Play® required. On the SS8 Plasma Rod™ Adapter, the Blue wires going to the two 3 pin connectors must be cut and capped off. Brown wire of the 3 pin connector should be cut where it meets the Red wire and relocated to Brown harness adapter wire. The Purple wire of the 3 pin connector should be cut where it meets the Red wire and relocated to Purple harness adapter wire. Connections can easily be made using Posi-Tap™ connectors (*Sold Separately*).

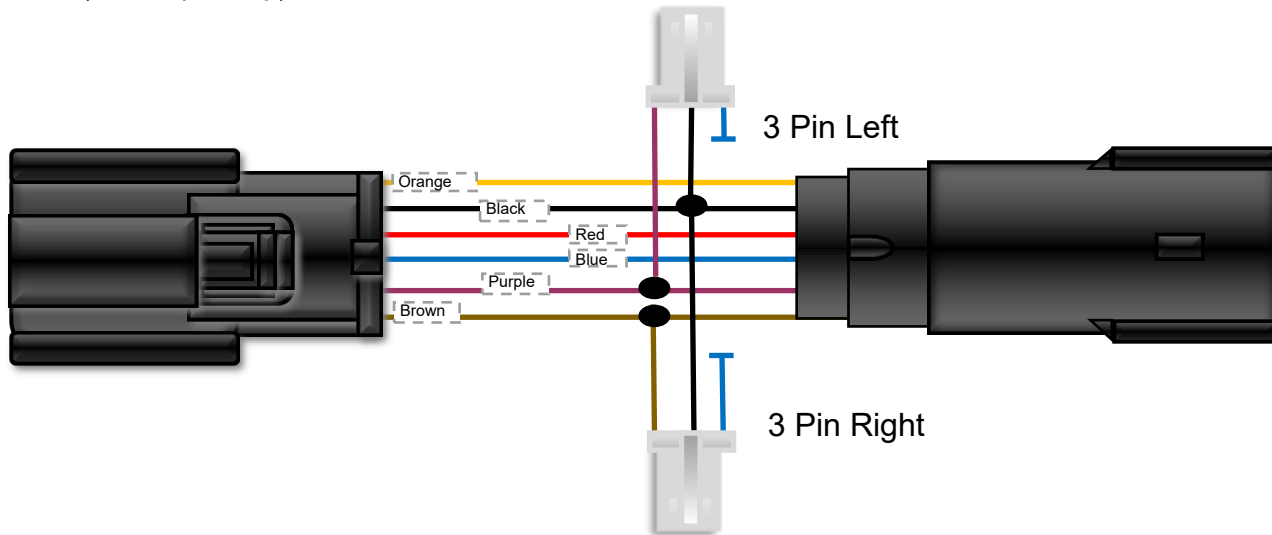

Run-Turn Configuration

*On the SS8 Plasma Rod™, the Brown wire of the 3 pin connector should be cut where it meets the Red wire and relocated to Brown wire and Purple wire of the 3 pin connector should be cut where it meets the Red wire and relocated to Purple connector wire. Connections can easily be made using Posi-Tap™ connectors (*Sold Separately*) See photo below for reference.

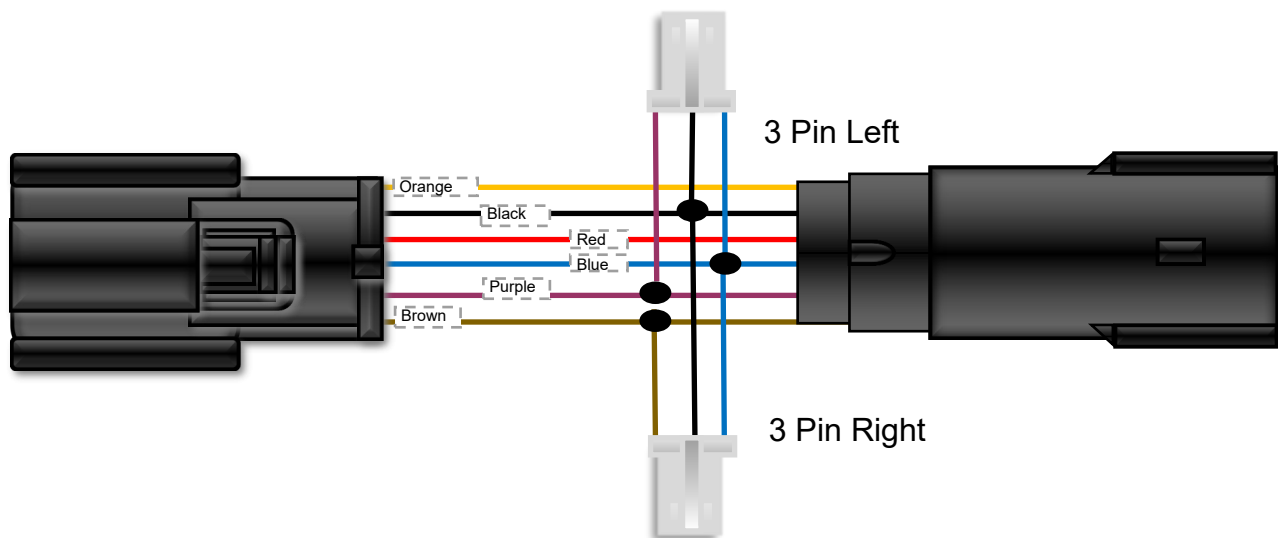

Questions? Call us at: 1 (800) 382-1388 M-TH 8:30AM-5:30PM / FR 9:30AM-5:30PM EST