



Custom Dynamics® TruFLEX® Integrated Plate Frame Installation Instructions

We thank you for purchasing the Custom Dynamics® TruFLEX® Integrated Plate Frame! Our products utilize the latest technology and high quality components to ensure you the brightest, most reliable LED's on the market. We offer one of the best warranty programs in the industry and we back our products with excellent customer support, if you have questions before or during installation of this product please call Custom Dynamics® at 1(800) 382-1388.

Part Number: TF06-C/B, TF07-C/B

Package Includes:

- TruFLEX® Integrated Frame (1)
- Dual Converter TFC2 (2)
- Mounting hardware (pack)

Optional Items Purchased Separately:

- Smart Triple Play® (Run, Brake, Turn Controller)
- MPR-BCM (Plug and play adapter for 2014-2020 HD® Touring)
- PTA2022 Posi-Tap™ connectors for wiring

Fits: Universal, Compatible with 12VDC systems with a negative ground.



Installation:

1. Mount license plate frame in desired location with the provided hardware. You may need to notch license plate to allow for wires to pass through, use heat shrink to protect wires from any sharp edges on plate mount.
2. Route wiring to suitable location for tapping into the bikes signal wiring. Take care to secure wiring so that it is not vulnerable to being pinched, pulled, cut or frayed.

⚠ ATTENTION ⚠

This product is designed and intended for use as auxiliary lighting only. It is NOT intended to replace any original equipment lighting installed on the vehicle and should not be used for that purpose. This product must be wired so that it does not interfere with any original equipment lighting.

Wiring Options

Depending on your bike's equipment, there are different options for the function of the Integrated TruFLEX®. The wiring diagrams on page 2 shows the function combinations. If you have a Run/brake/turn module installed, or for 2010-2013 Street Glide®/Road Glide® Customs, see the wiring diagrams on page 3. For 2014-2020 Street Glide®, see page 4. Please note that for some of the different functions, additional items may be required.

3. Connect all Black wires to good ground.
4. Connect the white wire to 12VDC running light power source.
5. With the Plate Frame oriented with the wires on the top, Purple is the left and Brown is the right. Connect them to 12VDC power source such as brake or turn signal wire, depending on use.
6. If Dual Converter is to be used, connect Purple (Left) and Brown (Right) wires on the TruFLEX® to the single red wire side of the dual converter. Connect red wire on opposite end to brake or turn signal power source and the orange to 12VDC running light source.
7. Check operation of the TruFLEX® Integrated Plate Frame in all modes.

Questions? Call us at: 1 (800) 382-1388 M-TH 8:30AM-5:30PM / FR 9:30AM-5:30PM EST

Installation Instructions - Page 2

TruFLEX® Plate Frame as Brake Only

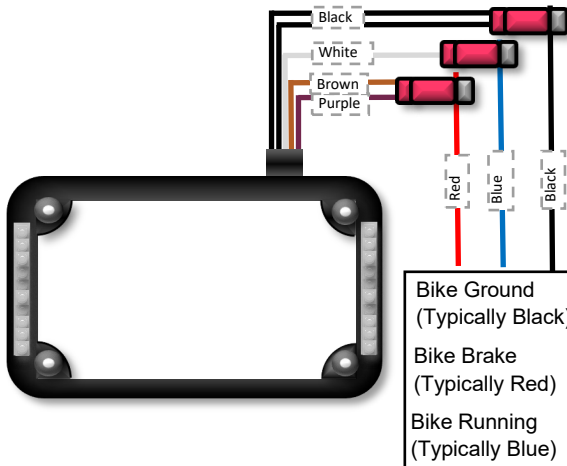

TruFLEX® Plate Frame as Turn Only

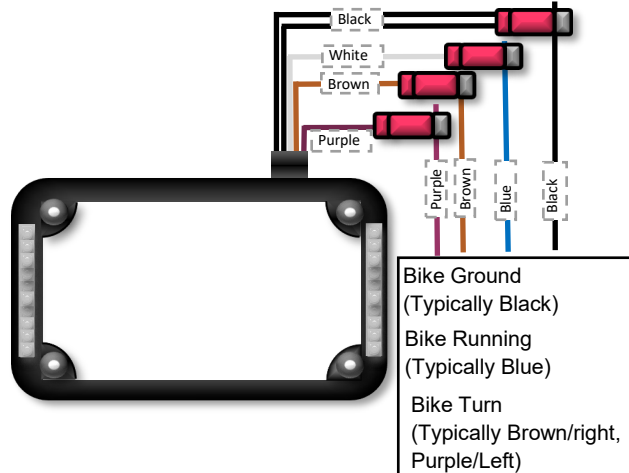

TruFLEX® Plate Frame as Run-Brake (Dual Converter Required)

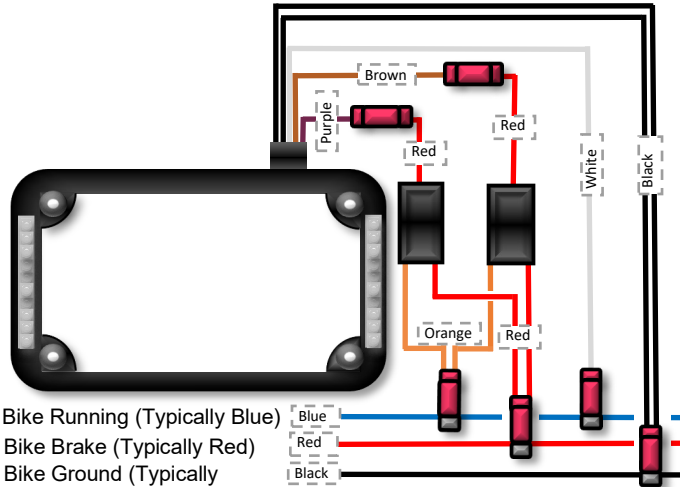

TruFLEX® Plate Frame as Run/Turn (Dual Converter Required)

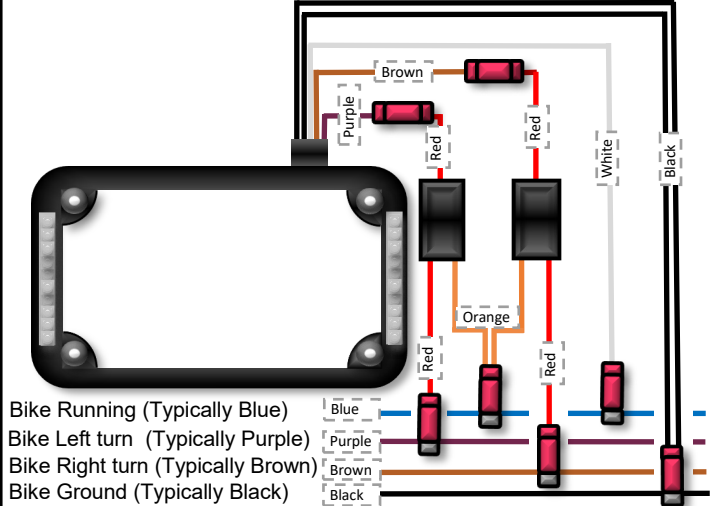

Wiring Diagram Legend

- x2 Black - Ground
- White - Tag Light LED +
- Brown - Right LED +
- Purple - Left LED +

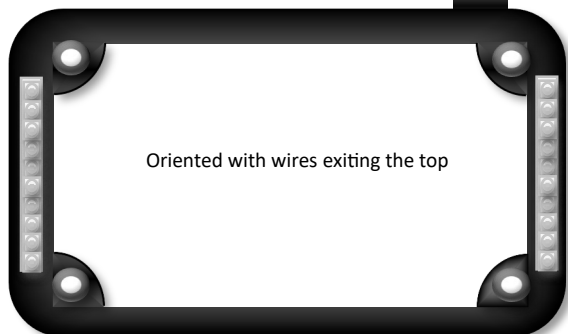
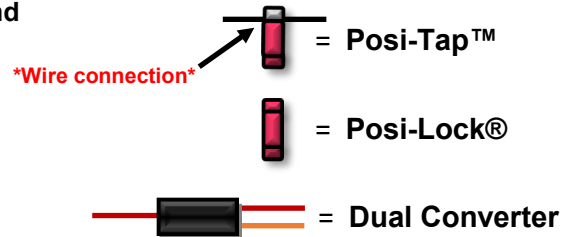

Note: Wire colors referenced in diagrams are based on the wiring harness colors for Harley-Davidson® Motorcycles. Please refer to your manufacturer service manual for wiring color codes for different makes. Always confirm your bike's wiring with a test light to make sure you are tapping into the correct wires.

Installation Instructions - Page 3

TruFLEX® Plate Frame as Run/Brake/Turn on Bike with After Market Run-Brake-Turn Controller

(Controller Sold Separately)

Running (Blue)
 Run, Brake and Left turn (Purple)
 Run, Brake and Right turn (Brown)
 Bike Ground (Typically Black)

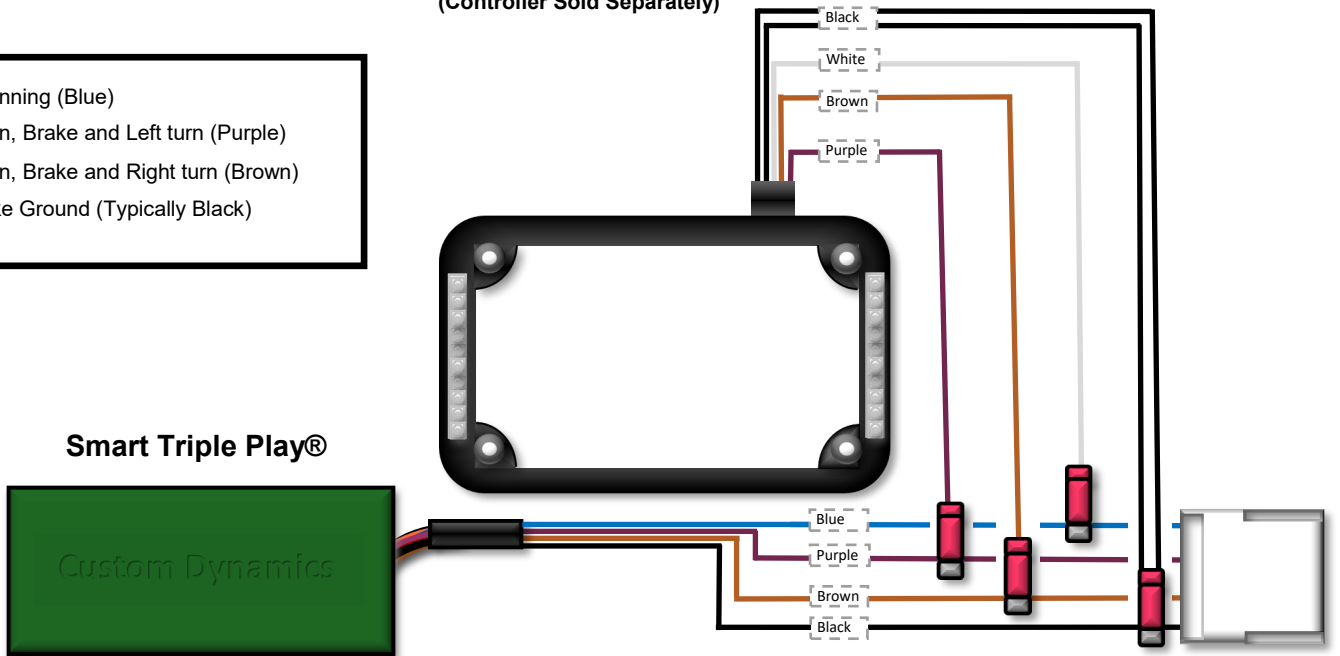

Input Side → Output Side (Towards Rear Fender)

TruFLEX® Plate Frame as Run/Brake/Turn on 2010-2013 Street Glide® & Road Glide® Custom

Output Side (right side of fender) remove back cover of stock tri-bar fender tip light for access. Use test light to determine which Purple is left turn signal and which is right turn signal.

*For brake/turn only function, omit dual converters and connect directly to turn and ground wires.

Bike Running (Blue)
 Bike Left Turn/Brake (Purple)
 Bike Right Turn/Brake (Purple)
 Bike Ground (Black)

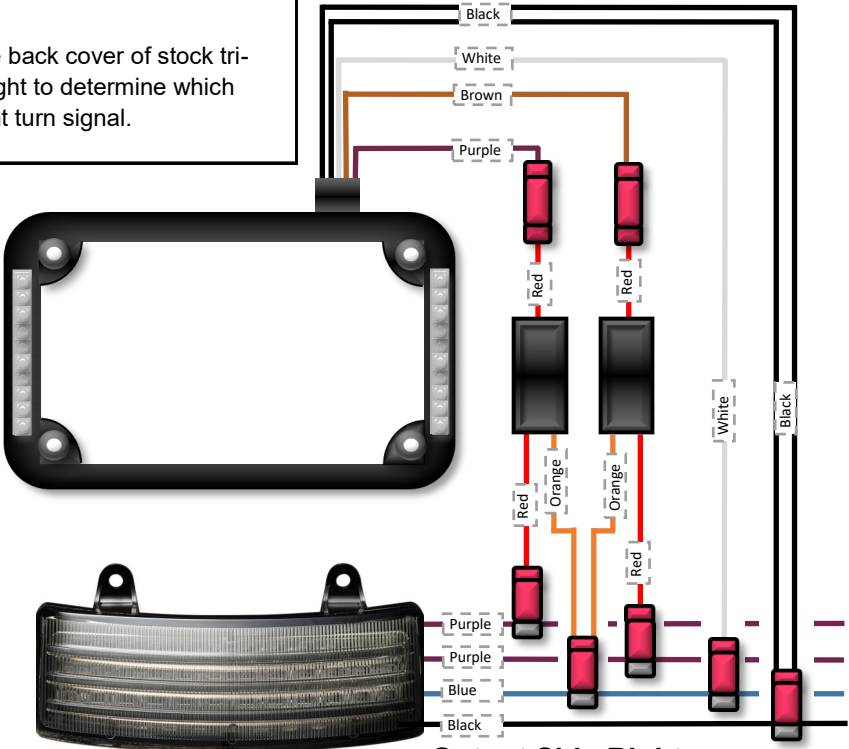

Input Side-Left → Output Side-Right

Questions? Call us at: 1 (800) 382-1388 M-TH 8:30AM-5:30PM / FR 9:30AM-5:30PM EST

Installation Instructions - Page 4

TruFLEX® Plate Frame as Run/Brake/Turn on 2014-2020 H-D™ Touring Models

MPR-BCM Diagram (Sold Separately) Wire Harness Color/Functions

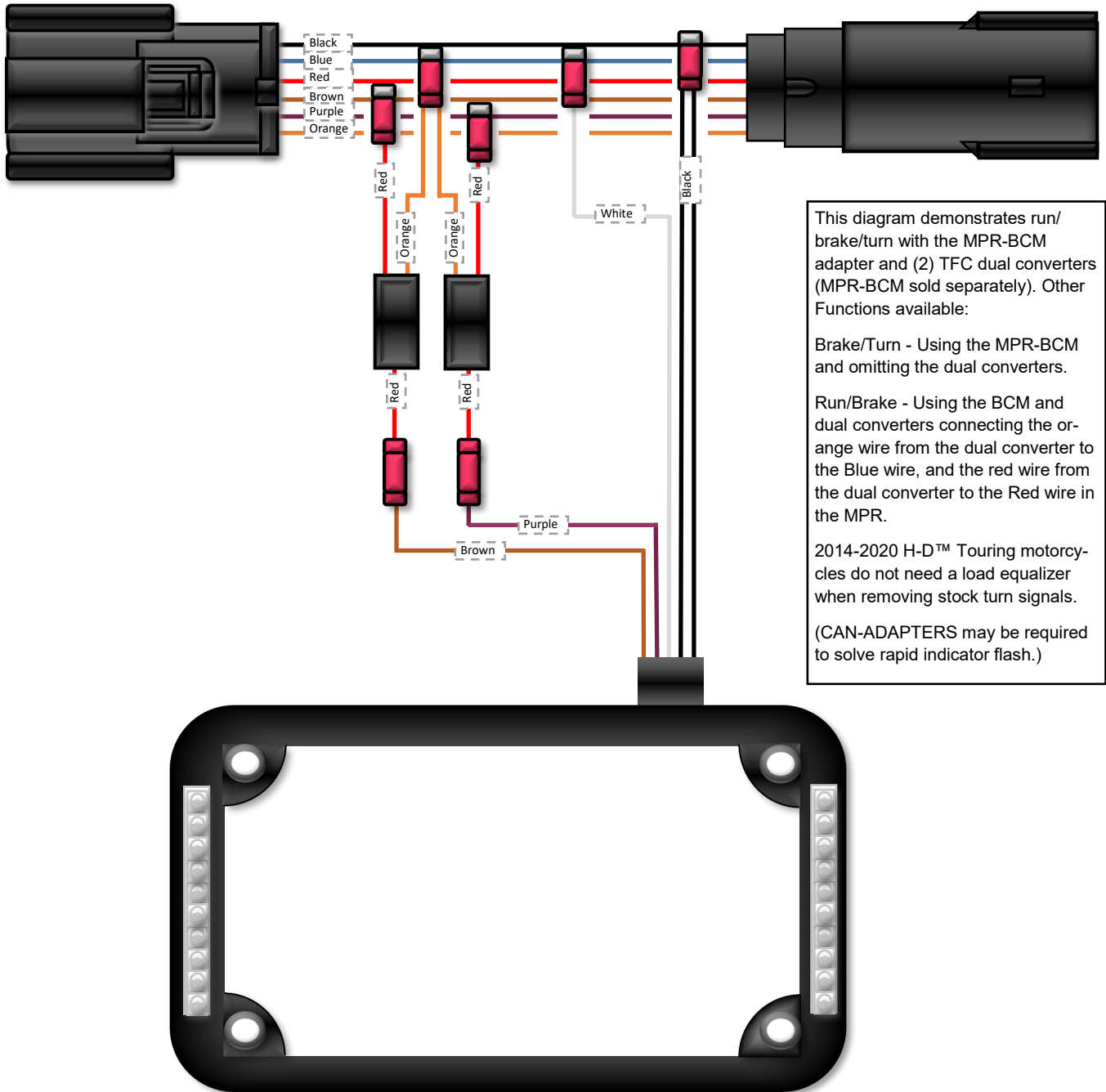

This diagram demonstrates run/brake/turn with the MPR-BCM adapter and (2) TFC dual converters (MPR-BCM sold separately). Other Functions available:

Brake/Turn - Using the MPR-BCM and omitting the dual converters.

Run/Brake - Using the BCM and dual converters connecting the orange wire from the dual converter to the Blue wire, and the red wire from the dual converter to the Red wire in the MPR.

2014-2020 H-D™ Touring motorcycles do not need a load equalizer when removing stock turn signals.

(CAN-ADAPTERS may be required to solve rapid indicator flash.)